

AGAINST THE FLOW:  
A NINETEENTH CENTURY WATERMILL IN CENTRAL FLORIDA

by

ELIZABETH GAYL CHANCE CAMPBELL

B.A. University of Central Florida, 2009

A thesis submitted in partial fulfillment of the requirements  
for the degree of Master of Arts  
in the Department of Anthropology  
in the College of Sciences  
at the University of Central Florida  
Orlando, FL

Spring Term

2017

## **ABSTRACT**

Small community watermills in Central Florida have gone virtually undocumented archaeologically and little is known about them except for written historical accounts. In an effort to determine how a settler in 1866 Florida would have used prior technological knowledge to design, build, and use a watermill I used a GIS predictive model to locate a previously undocumented watermill built in what is now Seminole County Florida. After the mill was located, excavations were conducted to determine the size of the mill structures, the industrial capacity of the mill, and determine the construction methods employed to build the mill.

For  
the Partin family,  
and the “others” that history threatens to forget.

## ACKNOWLEDGMENTS

This project would not have existed if not for Charlie Ross and his wife Marianna; he works hard to ensure the watermills of the Florida aren't forgotten, his dedication and skill gave me a huge leap in the right direction, and Marianna thank you for the warm hospitality and putting up with our mill talk. Thank you to Rachael Kangas for keeping me going when the doubts crept in, and of course my tireless crew from Hominids Anonymous. Hannah and Elyse Weldon for making me golf even when I swore I didn't have time and letting me crash in their spare room with little to no notice.

Dr. Barber thank you for taking me on and taking a chance on me you have been exceptionally been patient with me. I don't think I could be better prepared for what lies ahead, and I am grateful that you cared enough to make me go back and do it the right way. Thank you, Dr. Lester for your willingness to work across disciplines and making the RICHES program possible. Dr. Walker your knowledge of GIS and its archaeological applications has been invaluable and sparked my interest in all things mapping.

My Mom knew I was an anthropologist before I did, and has been pushing me towards this since I was twelve. She has seen me for who I am and has loved me unconditionally despite that. My Dad had me in the woods the minute I could keep up with him, and shared with me his finds; shell casings, cemeteries hidden in the woods, old fence lines and the stories that went with them. He never failed to answer my questions no matter how numerous or silly. Finally, my wife Lauren, you have been my confidant, supporter, photographer, and driving force over the last three years.

## TABLE OF CONTENTS

LIST OF FIGURES .....	vii
LIST OF TABLES .....	xii
CHAPTER ONE: INTRODUCTION .....	1
Theoretical Perspective .....	5
CHAPTER TWO: BACKGROUND .....	10
Industry .....	10
Industry in the South .....	10
Industry in Frontier Florida .....	13
Watermills .....	19
Mills in America .....	20
Mills in Florida .....	21
Mill Construction Techniques .....	22
Geography of Mill Areas .....	26
The Partins .....	31
CHAPTER THREE: FINDING THE MILL .....	35
GIS .....	35
Predictive Model .....	36
Mapping .....	41

CHAPTER FOUR: ARCHAEOLOGY OF THE MLL .....	45
Phase I: Pedestrian Survey .....	45
Phase II: Shovel Tests and Trenches .....	48
CHAPTER FIVE: RESULTS .....	53
Results .....	53
Trench01 .....	57
Trench02 .....	63
Shovel Tests .....	71
CHAPTER SIX: DISCUSSION/CONCLUSION .....	76
Discussion .....	76
Design of the Mill .....	76
Construction Material .....	85
Conclusion .....	87
APPENDIX A: STATE OF FLORIDA PERMIT AND SJRWMD EXEMPTION .....	94
APPENDIX B: FIELD FORMS .....	99
APPENDIX C: FIELD MAPS .....	105
LIST OF REFERENCES .....	108

## LIST OF FIGURES

Figure 1. Hugh G. Partin headstone located in the family cemetery less than half a mile from the mill site in what is now Maitland, Florida.....	1
Figure 2. 1870 Orange County Census, Hugh Partin is listed on line three with a self-described occupation of millwright (1870 Census Bureau records).....	5
Figure 3. The Piedmont area of the Southeast where a majority of recorded large production mill sites can be found due to the water power produced by the mountainous region. ....	13
Figure 4. Map of Florida showing the modern I-10 corridor, where a large majority of the population of Florida lived until the mid-1860's.....	14
Figure 5. Arcadia Mill Complex in relation to the Blackwater river. The area has been studied intensely by Brian Rucker (1988) and John Phillips (1998). ....	16
Figure 6. Fort Gatlins location in relation to modern City of Orlando. ....	18
Figure 7. Four types of watermill construction; undershot is the type most commonly found in small community mills with low flowing water sources (Lindsey 1996). ....	23
Figure 8. Undershot waterwheel showing water moving through the sluice and the relative location of an associated millhouse (Australian Education Resources).....	23
Figure 9. Image of log dam found most often in sandy bottom rivers and creeks. (Leffel 1881:9) .....	25
Figure 10. St. Johns river basin (map courtesy of the St. Johns River Water Management District website). ....	29
Figure 11. Average volume of water for Howell Creek from 1970 to present. Volume measured in Cubic Feet per Second (CFS) (Seminole Water Atlas 2016). ....	30

Figure 12. Howell Creek basin from point of origin to the St. Johns river. ....	30
Figure 13. Partin family’s stops on their way to Orange county Florida numbered in order of arrival, the family started in Tattnall where Partin was raised then moved to St. Mary’s bend, Sanderson, FL, back to Georgia for a short period of time, and finally settles in Central Florida. ....	32
Figure 14. Predictive model layer with property ownership of sections, in relation to Howell Creek. ....	38
Figure 15. Fifteen-mile radius around modern City of Orlando and hydrology information and historic railroad locations. ....	39
Figure 16. Properties with access to Howell Creek. ....	40
Figure 17. Final map built using the predictive model. Four properties were shown to have sufficient water available, but only one had the ownership history to support the historic record. (1890 survey map downloaded from the UCF RICHES archive [RICHES of Central Florida 2011]) ....	41
Figure 18. Layout of features recorded before excavation. ....	43
Figure 19. Pedestrian survey areas upstream and downstream from the mill. ....	46
Figure 20. Planview of mill site, trenches and shovel tests are shown. ....	50
Figure 21. Trench01, with labeled sections. ....	51
Figure 22. Trench02, with labeled sections. ....	51
Figure 23. Existing mill foundation, walls are labeled with their feature numbers. ....	54
Figure 24. Visible metal reinforcement in concrete block on feature PMF07. ....	55



Figure 25. Portion of axle that protrudes over gear box and contains the attachment points for a potential gear. ....	55
Figure 26. Map of all features recorded at mill site. Wall debris areas were not designated as features. ....	56
Figure 27. Profile view of trench01 showing new construction on top of older construction. Headrace is visible in center of picture. ....	57
Figure 28. Plan view of trench01, with sections labeled. ....	57
Figure 29. Wood frame uncovered next to wall, highlighted area shows wood frame with poured concrete filling the space between the wall and the frame. ....	58
Figure 30. Headrace area before excavation, highlighted area shows tree root that has disturbed the area. ....	59
Figure 31. Two samples of concrete recovered from trench01A. Artifact A, shows a solid material with no larger aggregate pieces. Artifact B, shows concrete with large pieces of white stone aggregate visible. ....	61
Figure 32. PMFea03.1, Piece of hand collected headrace, material is broad and flat without any large aggregate pieces. Arrow points to metal inside of material. ....	61
Figure 33. Small pieces of concrete with visible mold markings. ....	61
Figure 34. Headrace fully excavated. Photo shows depth of south side of headrace in relation to the original soil level. ....	62
Figure 35. Headrace at opening to sluice. A, shows the area where the headrace and wall would have touched but not connected structurally. B, shows the support structure put in place to the north of the headrace. ....	63

Figure 36. Gear box before excavation. ....	64
Figure 37. Trench02 and sections A and B labeled. ....	65
Figure 38. Metal fragments from gear attachments in situ and drawing of gear attachment as it may have looked (Reynolds 1983:289).....	66
Figure 39. Pieces of gear attachment being held up to axle for context of possible attachment points. ....	67
Figure 40. Screw recovered while excavating trench02A (gear box).....	68
Figure 41. Example of plaster and lath material recovered in trench02A.....	68
Figure 42. Concrete with tar paper and green paint on opposite sides. ....	69
Figure 43. Floor of gear box. Wood inserts are visible and run parallel to each other. One wood plank seems to line up with a drain hole in the east wall of the box. Reason for wood panels is unknown though given the alignment with the gear attachment arms it may have been related to the gear placement. ....	70
Figure 44. Drain hole in the eastern wall of the gear box. ....	70
Figure 45. All units that were excavated and all shovel tests that were completed.....	71
Figure 46. Metal found in shovel test 13.....	72
Figure 47. Planview of south debris field, ST08 and ST09 revealed the extent of this area. ....	73
Figure 48. Wall Debris showing white stone aggregate and mold markings. ....	73
Figure 49. Board found in shovel test 14. ....	74
Figure 50. Nail recovered from top of wood beam found in a shovel test. The nail has a twist in the body that is visible is most likely a modern nail. ....	75

Figure 51. Headrace shown on the right connects to the sluice below the center of the wheel or in this case the observable axle.....78

Figure 52. Rendering of headrace with dimensions.....79

Figure 53. Rendering of sluice and axle with dimensions .....79

Figure 54. Maximum range of wheel radius.....80

Figure 55. Areas measured to figure out volume for mill. ....82

Figure 56. Brick recovered from creek with Makers mark on it. Stevens Kaofrax was traced to Middle Georgia. ....87

Figure 57. 1940 Aerial photo of mill area and cemetery. Proposed settlement area is also highlighted. ....92

## LIST OF TABLES

Table 1 Similarities in the amount of annual income between the South and Midwest in the mid-1800's. (Cohn 1980).....	12
Table 2 Central Florida's population increase between 1850 and 1900 (Kendrick 1976:150).....	18
Table 3 Comparison of rainfall in Florida to that of New England in the late 1800's (Hunter 1979:122).....	27
Table 4 Count of construction material found in debris area located in the creek. ....	47
Table 5 Type of concrete recovered, counted and weighed in the lab. ....	60

## CHAPTER ONE: INTRODUCTION

For anyone who has lived in or traveled to Central Florida, the indelible portrait of resorts and alligators is what comes to mind most often. While that is mostly true for the twentieth century and certainly true for Seminole and Orange counties, it is not the comprehensive history of the area. In fact, much more lies below the surface of the pavement and throngs of tourists, and in many cases, it is right under our noses. For example, the ruins of a watermill built by Hugh G. Partin (Figure 1) still exists in Seminole County. Partin was a millwright and son of an Irish immigrant, who traveled to Central Florida during the Civil War and eventually, in 1866, would make his home along Howell Creek where he would build his mill and a legacy.



*Figure 1. Hugh G. Partin headstone located in the family cemetery less than half a mile from the mill site in Maitland, Florida.*

Motivation to complete this project was driven by the desire to bring to light this all but forgotten piece of local history and reevaluate Hugh Partin's place in history. Throughout this process, I found it necessary to justify that a watermill could have existed in Central Florida and that it was indeed feasible. This need for justification comes from a common misconception that

Florida does not have the water power to support the same watermills that can be found in the Northeast. This misconception is, in fact, not completely wrong. The success of the industrial age in the North and the agricultural dominance of the South, throughout the eighteenth and nineteenth century, does create a narrative contrary to water-powered industry in the South that is easily defended. The large waterpower industry most closely associated with the South is concentrated in the Piedmont mountain range: north Georgia and eastern parts of the Carolinas. Throughout the course of this research, I will endeavor to expel this narrative: exploring how Hugh Partin brought his technical knowledge with him to a virtual frontier, utilized that technical know-how to build a successful watermill, and thereby altered Central Florida's economy and his position in society.

In order to understand how Hugh Partin and his mill affected change in Central Florida, and to ensure that the mill he built is properly documented, several objectives would need to be met. The central research question is:

How was the Partin mill designed, built, and used to facilitate economic activity in its local neighborhood and broader community?

In order to answer this question, I achieved the following:

- Contextualize the mill in relation to the neighboring waterway.
- Identify the mill dam and pond.
- Determine the size of the mill structures and the industrial capacity of the mill.
- Determine the construction methods employed to build the mill.
- Find the mill house and determine its extent, if possible.

- Identify any material remains indicative of the people who used the mill.
- Place the mill and associated cemetery on the Florida Master Site File.

These objectives were met through fieldwork and mapping technology, such as on-site excavations and predictive model-building. The existing mill, after being located with the help of a predictive model built in ArcGIS, was contextualized in relation to the neighboring waterway and that information was then used to build an understanding of the size and capabilities of the mill based on the water resources available. An attempt was also made to identify a mill dam and pond. The information gathered about the water resources and the mill's location in relation to the creek was used, along with data about the size of any associated mill structures, to determine the industrial capacity of the mill. The construction methods employed by Hugh Partin to build the mill and factors contributing to those decisions were analyzed through the identification of material remains that may have been associated with the mill house, and a determination of the mill house's extent was attempted. Finally, this research led to the mill and nearby family burial plot to be listed on the Florida Master Site File.

In this chapter, I will discuss the theoretical approaches I will use to give context to the material remains that will be the focus of my fieldwork. These theoretical approaches will also inform the methods with which I choose to examine those material remains. Chapter 2 will lay out a summary background of industry in the South, watermills in the South and Florida, and of Hugh Partin and the other political players of the era. This chapter will provide the historical context for the mill and connect the people involved to each other and the world they live in; the added bonus of having a site that temporally fits within the historical record is the ability to add a voice, through historical records, to the people involved. Some of the information discovered

during the historical research for this project is not verifiable through the material record and may only serve to inform or add context to the data collected.

Chapter 3 outlines the use of ArcGIS to create a predictive model to locate Partin's mill. Its location was unknown and undocumented in historical records or on the Florida Master Site File at the start of this research. The model built was successful in finding the mill and Chapter 3 is intended to be a guide on how to recreate the model for future research. Chapter 4 covers the field and excavation methods used in order to answer the more specific questions about the mill itself. Because there are existing and visible features of the mill, a detailed survey of the mill and the surrounding area was conducted using a GPS and a total station to record data points. After the visible structure was documented, trenches and shovel tests were used to excavate and uncover any prior mill features that may have been part of the original structure.

Chapter 5 contains the results and relevant information gathered from the surveying of the site and the subsequent excavations. It is in this chapter that the artifacts recovered and the features that were documented are discussed and analyzed. A detailed description of each unit is provided and the shovel tests are discussed. In Chapter 6, I will discuss my findings from the analysis of measurements taken during field work, and use them to determine the mill size and capacity. I will also conclude that through the use of technical knowledge and social agency, Hugh Partin was able to incorporate a technology in an attempt, a successful one at that, to influence the economic and political activity of the area.



Theoretical Perspective

In this section, the technological knowledge of building and running a mill that Hugh Partin possessed and his identity as a millwright will be examined to determine how it would have contributed to his rise in political standing and to the economic growth of Central Florida. Through historical records, I was able to establish that Hugh Partin identified himself as a millwright (Figure 2) and became a member of local politics after having established his mill. Given Partin's identity as a millwright and the technological knowledge that he possessed, a theoretical base that focused on technology and the social actors that used technology as a means of interacting socially and politically was needed in order to interpret the data about the mill I would be collecting.

Page No. 8      Inquiries numbered 7, 16, and 17 are not to be asked in respect to infants. Inquiries numbered 11, 12, 15, 16, 17, 19, and 20 are to be answered (if at all) merely by an affirmative mark, as /.

SCHEDULE I.—Inhabitants in Division No. 17, in the County of Orange, State of Florida, enumerated by me on the 25<sup>th</sup> day of June, 1870.

Post Office: Orlando      William B. Watson, Ass't Marshal.

1	2	3	4			7	8		10	11		13	14	15	16	17	18	19	20	
			4	5	6		8	9		11	12									
		<i>Mrs. Mary W.</i>	<i>11</i>	<i>7</i>	<i>1</i>				<i>Florida</i>											
		<i>Smith, Harriet</i>	<i>40</i>	<i>10</i>	<i>1</i>				<i>Georgia</i>											
<i>31</i>	<i>73</i>	<i>Partin, Hugh</i>	<i>63</i>	<i>10</i>	<i>1</i>	<i>Millwright</i>	<i>500</i>	<i>750</i>	<i>"</i>									<i>/</i>		
		<i>" Nancy</i>	<i>30</i>	<i>2</i>	<i>1</i>	<i>Keeping House</i>			<i>"</i>											
		<i>" John</i>	<i>20</i>	<i>10</i>	<i>1</i>				<i>"</i>											
		<i>" George</i>	<i>18</i>	<i>7</i>	<i>1</i>				<i>Florida</i>											
<i>32</i>	<i>74</i>	<i>Partin, Harriet</i>	<i>86</i>	<i>10</i>	<i>1</i>	<i>Widow</i>	<i>300</i>	<i>300</i>	<i>Georgia</i>									<i>/</i>		
		<i>" Ruth</i>	<i>30</i>	<i>7</i>	<i>1</i>	<i>Keeping House</i>			<i>"</i>											
		<i>" Hugh</i>	<i>10</i>	<i>10</i>	<i>1</i>				<i>"</i>											
		<i>" William</i>	<i>6</i>	<i>10</i>	<i>1</i>				<i>Florida</i>											
		<i>" Robert</i>	<i>3</i>	<i>10</i>	<i>1</i>				<i>"</i>											
		<i>" James</i>	<i>2</i>	<i>10</i>	<i>1</i>				<i>"</i>											

Figure 2. 1870 Orange County Census, Hugh Partin is listed on line three with a self-described occupation of millwright (1870 Census Bureau records).

Technology is defined as practical knowledge of science applied to practical purposes, and more specifically in archaeology, as behaviors that are grounded in material objects that both influence and are influenced by how the agents of technology creation use that practical knowledge (Dobres 2000:10). Watermills are an example of technology and the millwrights that built them are the technicians. Though most technology-based theories are used to analyze ancient technologies such as tool making, it is overwhelmingly about the technologies that make up the material record that an archaeologist is concerned with (Dobres 2010:103), regardless of the form that technology may take. It can be argued that the material remains of the watermill, and the use of it as a tool to create other material remains, are in fact technology and the millwright, as well, a technician with agency just as much as any ancient person knapping flint. This connection of Hugh Partin as a technician and the watermill as a technology allows for the use of a technology based theory.

Having established that the watermill is a technology that has been enacted in a social setting, it is imperative to understand how that technology and the economy of the area interacted. It is also vital to understand the way Partin, and the community as a whole benefitted from this technology. The connection between technology and economic growth will be established in the rest of this section using Marxist ideas of relations of production and productive forces (Marx 1859). I will then draw a connection to others who have used these ideas of production and social standing and applied them to archaeology (Cresswell 1993; Schiffer 1992), using *chaîne opératoire* to understand how the creation of technology both influenced the community and how Partin influenced the technology. Finally, I will draw on

these ideas to analyze how Hugh Partin used his technological knowledge and skill to create an economic influence on the community and convert that into political power.

Karl Marx, in both *Capital: Critique of Political Economy* (1867) and *A Contribution to the Critique of Political Economy* (1859), discusses how an individual creates political and societal relationships with others through production of material objects. Through material, humans satisfy basic needs and through advances in material humans move beyond basic subsistence. Relationships with economies and with a political body, such as the Central Florida community in this case, are entrenched in the material aspects of everyday life (Marx 1859:i) and more specifically the production of the goods and products that Partin would have produced. It is through the growth of labor and technology that subsistence becomes an economy and allows a community to develop into a political body. Marx (1867:929) notes that through systematic and joined effort developments in the technology of production lead to the connection of humans into what he calls social production which leads to the “economizing of all means of production.”

In order to archaeologically frame the mill and how it should be analyzed, I turn to *chaîne opératoire*. Two definitions of *chaîne opératoire* are applicable to my research: first as a reconstruction of a technology within a specific archaeological site context, second, more precisely, as the technical gestures or decisions made to satisfy the needs of production (Sellett 1993:63) and in this case a capitalistic endeavor. Dobres (2010:106-107) defends *chaîne opératoire* as a conceptual framework for understanding the connection between people and products and, more specifically, the outside or social and cognitive factors shaping technology or technological action. *Chaîne opératoire* as an encompassing methodology to analyze the data

collected through methods such as survey and excavations gives credibility to my claim that Partin used his technological knowledge to create a position of authority or importance for himself in the social relationships of the community, specifically within politics.

Establishing that the mill is a technology connected to a substantial community-based economy, and examining its construction, and later repair, through a *chaîne opératoire* methodology is not enough to fully answer the broader question of how the mill influenced the social position of Partin and the community around him. For this I turn to Earle (2000) who looked at the role that ownership of property and resources played in participation in economies and other social institutions, such as politics. By owning and controlling property, in this case a mill and the surrounding land, the owner becomes entrenched in the economy of the area and connected to a social institution (Bell 1998, Earle 2000, and Neal 1998), in this case the political institution. The most meaningful and applicable institution to my study is the political institution which Hugh Partin participated in, ownership of wealth or in this case technology and resources created a symbolic connection to social capital for control within political spheres (Earle 2000:45; Smith 1987:298). The land that Partin gained for the mill through the Internal Improvement Land Grant and sales from other land owners in the area along with the subsequent development of the surrounding area, is evidence that through simple possession of land and technology Partin was able to entrench himself into the politics of the area, in essence, his position as a county commissioner. His control of the power of milling grist and cutting lumber in turn created social capital.

In an attempt to answer the last part of my research question, how did the mill facilitate economic activity in the local neighborhood and the broader community and how did that

translate into political power for Partin, I used two theoretical perspectives: *chaîne opératoire* and Marxist connections between production and political connections. Through *chaîne opératoire* the reconstruction of the mill and its capabilities, as outlined in Chapter 6, reveal the decisions made by Partin to further his role in the community through a capitalistic venture. Using the existing mill structure to understand the size and potential power of the mill so that decisions made by Partin about the type of mill he built can be understood in context and comprehensively. Through Marx's connection of technology and labor to political and social relationships Partin's role in the community becomes clearer and the mill's part in that role can be defined. This is found in the historical background for Partin and the mill, discussed in Chapter 2.

## **CHAPTER TWO: HISTORICAL BACKGROUND**

Throughout this chapter, a short history of Southern industry, watermills in the South, and nineteenth century Central Florida will provide context for the Florida that Partin moved into and the Central Florida that he sought to build. Even though northern large industrial watermills were undeniably influential to the United States of 1860, they are beyond the scope of this work and will only be mentioned to give context to the smaller mills more common in the South. The details about small southern mills covered in this chapter, specifically looking at the history of mills in the South, construction, use, and greater impact on their community, will connect the Partin settlement to the greater southern industry and the emerging capitalist environment of post-bellum Florida. An attempt will also be made to reconstruct the geography and environment of Central Florida and Howell Creek as it may have been in 1866.

### Industry

Watermills in the South were not a new concept, as can be seen in every region of Georgia and other coastal southern states. They came to Northern Florida beginning with the first occupation of the Spanish and continued in that area until the early part of the Twentieth Century (Phillips 1998:148). It should not be surprising that a small watermill could have and did flourish in burgeoning Orlando. This section specifically looks at the water-powered industry of the South in the years before and during the Civil War.

### Industry in the South

The Civil-War era South brings to mind an era of large plantations with a focus on agriculture and slave labor, and little to no indication of the type of industry that one might think of with regards to the North. Part of this narrative may come from the fact that much of the

South was still considered frontier while the north was financially and politically outpacing the South's development. Rupert Vance (1968:62) describes the Southerner moving through stages of progress: "the woods rover, the cattle raiser, and the farmer", and just before the Civil War emerging as the plantation owner. While this may be one narrative, there are other truths that are often overlooked. For example, spinning of textiles has been recorded as early as 1790 in South Carolina, and North Carolina had its first mill built in 1813 (Vance 1968:289). Vance (1968:289) states that in an attempt to regain their economic footing, as well as provide jobs to "poor whites" after reconstruction, an opportunity was seized by many in the South to "exercise the belief that only Yankees could manage cotton mills."

Given the amount of water resources and populations that would have required building materials and grain milled, it is inappropriate for the South to be portrayed as lacking industry and technology. This idea is expressed by Raymond Cohn (1980), who in his study of the Midwest and South revealed striking similarities in manufacturing between the two regions (Table 2.1). Cohn (1980) in his article discussing manufacturing in the South and the Midwest, points out that economists such as Douglass North (1966), who describe the Midwest as more advanced in regards to manufacturing, is disregarding evidence to the contrary. In a comparison of all manufacturing, the South gained a larger percentage of their income from manufacturing products that were to be consumed outside of small community use (Table 1). Whether for local use or market-oriented manufacturing, which is the production of goods destined for a larger consumer market. Cohn (1980: 83) states that the notion of a lack of economic strength based on local industry comes from the idea that almost everything produced in the South was agriculture and export-oriented and therefore other forms of production were often overlooked. The South

may not have been exporting all of their products, but the products they were producing, although for local consumers, were just as vital to their industrial status as anything produced for export.

*Table 1. Similarities in the amount of annual income between the South and Midwest in the 1850's. (Cohn 1980)*

Region	All Manufacturing	Market-Oriented Manufacturing	% of income from manufacturing
South	\$74,230,932	\$42,961,902	57.88%
Mid-West	\$132,416,777	\$73,726,125	55.68%

Across the South, whole populations of whites did not participate in the plantation economy and many large cities in the South were participating in industry based economies (Beatty 1987; Haase 1984; Manganiello 2015). For example, Kenneth Sokoloff and Viken Tchakerian (1997) point out that 85% of the region's manufacturing came from the 10% of the South's population that lived in urban areas. The Piedmont area, which encompasses the cities of Augusta, Richmond, and areas in Tennessee, participated in industrial manufacturing similar to that of the North (Figure 3). The 1840 census recorded 10,612 gristmills in the South alone along with 6,568 sawmills (Haase 1984:285). In 1840, the ratio of mills to people differed from the North to the South by only 20 percent; in the North, there was one mill for every 280 people whereas in the South there was one mill for every 350 people (Hunter 1979:38), it is not clear whether or not this figure included slave populations or the size of the mills being counted. Though many of these small rural mills started out as cash or barter mills that planters would build to supplement their crop earnings. They became more market-based production centers as



progress was made in cotton varieties and ginning processes; mill operators or millwrights were thrown into the market economy (Manganiello 2015:27).

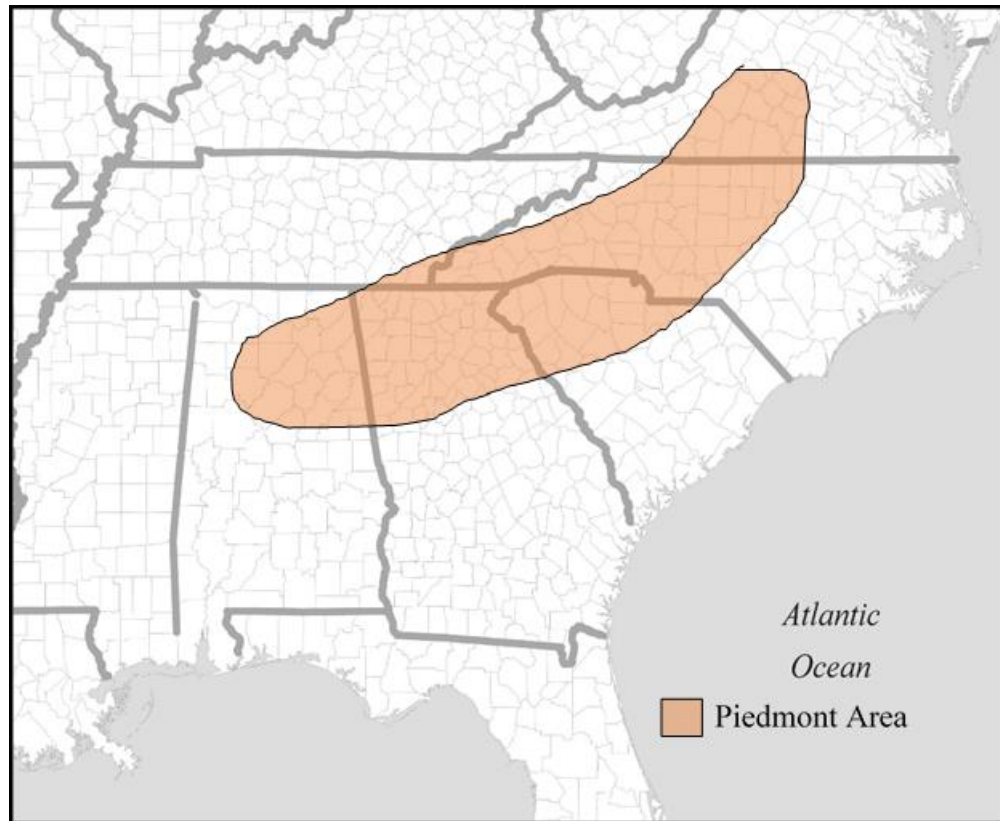

Figure 3. The Piedmont area of the Southeast where a majority of recorded large production mill sites can be found due to the water power produced by the mountainous region.

### Industry in Frontier Florida

Florida has a long and storied history: two occupations by the Spanish, one by the British, and finally statehood in 1845. It entered the Union with a population of 5,795 and one railroad twenty-three miles long running from Tallahassee to St. Marks (Cash 1938:379). Most of Florida remained uninhabitable to settlers well into the 1800's and what little industry or agriculture was able to gain a foot hold remained north of the present-day Interstate 10 corridor (Figure 4). David Yulee increased the amount of railroad miles from 23 to 350 by 1860, making

Florida more easily accessible, and up for purchase by personally influencing the award of an internal improvement land grant (Cash 1938:379-380). With the introduction of railroads, areas of Florida that had once been difficult to reach became more accessible; early on river ferries were the main access to a market for products, requiring that manufacturers like mills and turpentine farms be located near waterways (Cash 1938:381). The Internal Improvement Land Grant made it relatively inexpensive to settle these previously unsettled areas, and opened up a new frontier. Evidence of his influence can be seen in a message from the Governor to the general assembly in 1859:

Saw mills and turpentine plantations are dotting the lines of road in sections heretofore inaccessible, and furnish employment to a large number of industrious citizens, and give value to that class of lands which have been regarded until of late as valueless – Governor Madison Starke Perry [Cash 1938:381]

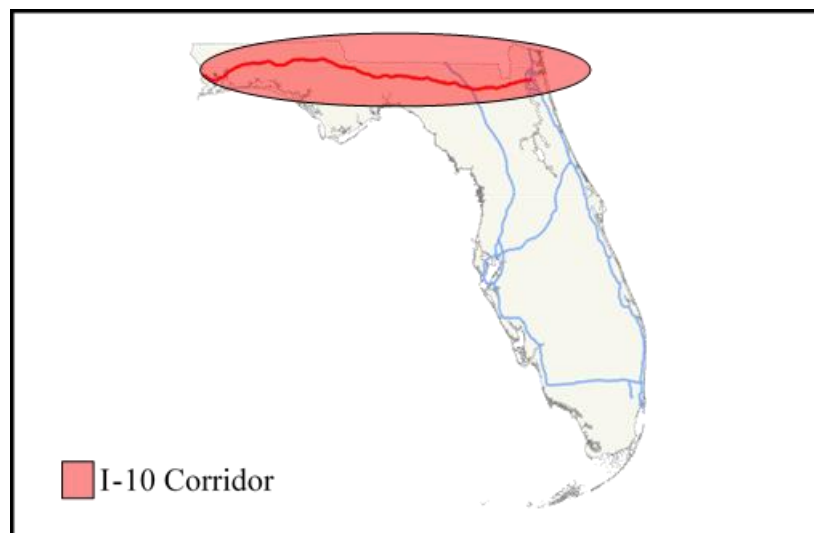

Figure 4. Map of Florida showing the modern I-10 corridor, where a large majority of the population of Florida lived until the mid-1860's. I-10 was used merely as a reference point for modern context of the area inhabited by early settlers to Florida.

The most prevalent industrial area of frontier Florida was the Arcadia and Blackwater area of Pensacola (Figure 5). First settled in 1791 by Juan de la Rúa, who with a land grant began clearing the area around a small natural narrow channel on a small creek that feeds into the Blackwater River (Rucker 1988:147). Here he built a sawmill to take advantage of the amount of virgin pine and the easy access to the Pensacola port via the Blackwater river (Rucker 1988:148). This is only the beginning of the milling industry in the area. John C. Phillips (1998:143) studied the Arcadia Mill Complex and located fifty-eight other separate mill sites ranging from the early British occupation to the Great Depression. These mills served predominately as lumber mills, providing pine to the growing southern region, and the Arcadia complex was unique in that it produced textiles using water power and slave labor. Many of these have been documented archaeologically and have provided a wealth of information on early Florida mills (Phillips 1998; Rucker 1988).

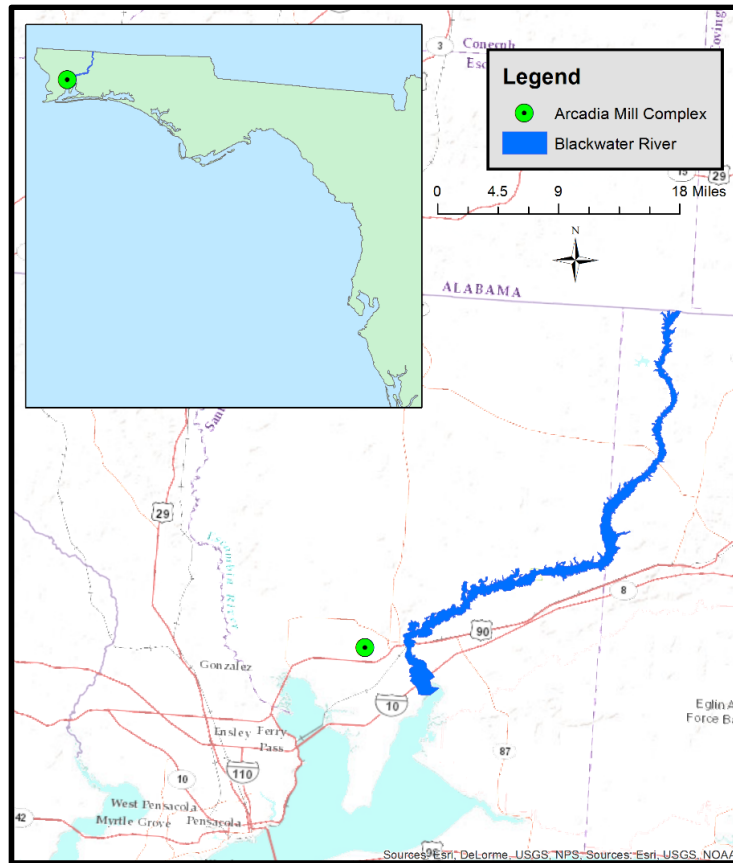

Figure 5. Arcadia Mill Complex in relation to the Blackwater river. The area has been studied intensely by Brian Rucker (1988) and John Phillips (1998).

In other areas, such as Jacksonville, William M. Jones surveyed fifteen sites, and excavated the Hewitt mill, a British-era mill site (Jones 1981:1). The Hewitt mill was built in the 1700's and served as a lumber mill for the British colony (Jones 1981:5). In the process of researching the Partin mill, the mention of other mills has been uncovered in texts as well as informants contacting me about mill sites that have gone undocumented. In an article to the *Cincinnati Commercial* written in 1875, a well-known Florida author, William Wallace Harney, describes how within every neighborhood there is a working mill and even goes on to describe in other articles specific mills like one that was located in what is now Wekiva Springs State Park (Wehr 2014).

In her account of Central Florida history, Eve Bacon (1975) outlines the settlement of the area beginning when European settlers and soldiers first settled the area now known as Seminole and Orange counties in the 1820's, and through a treaty in 1832 with the Seminoles established Fort Gatlin in November of 1838. In 1843, Aaron and Isaac Jernigan settled along the shores of Lake Holden, naming the area Jernigan, which was located in what was then known as Mosquito County. After statehood, the county was renamed to Orange and divided into several other counties between 1845-1850. Fort Gatlin was abandoned in 1849 due to the decrease in Native American attacks, and in 1850 John Worthington built the first log house within the modern Orlando city limits (Figure 6). A post office was reestablished in 1866, after having been discontinued in 1861. In 1863, a log court house was built which led to the reestablishment of civil government (Bacon 1975: iv). Between the years of 1850 and 1900, the population of Orange county increased by over 10,000 and Orlando increased by 3,000 from 1880 to 1900 (Table 2) (Kendrick 1976:150).



Figure 6. Fort Gatlin's location in relation to modern City of Orlando.

Table 2. Central Florida's population increase between 1850 and 1900 (Kendrick 1976:150)

	1850	1860	1870	1880	1890	1900
Orange Co.	466	987	2195	6618	12584	11374
Orlando				200	2856	2481

In the years before the Civil War, beef cattle and cotton were the main products being produced in Central Florida. They were highly successful, and settlers moved in looking to build agricultural dynasties from these industries. By 1860, Orlando was surrounded by several cotton plantations and ranging cattle; an average acre plot could yield a 330-pound bale of long fibre

fine cotton (Bacon 1975:19). In the early days, there was little infrastructure and, though most had the means to build a log cabin, many settled with a palmetto hut, and spent the year raising cotton and cattle. Prior to 1863, the cattle were left free to roam and were rounded up once a year to be taken to Tampa for purchase by Cuba (Bacon 1975:20).

Florida seceded from the Union in 1861 and Orlando sent a company of soldiers to the fight, leaving the workforce thin. Along with a blockade of basic supplies being brought into the area, the federal army blocked the shipment of cattle out of the area destined for sale in Cuba hindering the continued growth of the once-expanding and prosperous cattle industry of Orlando (Bacon 1975:24). The lack of supplies, resources, and a decimated workforce demolished the cotton industry. The area that was beginning to grow before the Civil War was almost on the brink of disaster by 1865, but 1866 and the end of the Civil War saw an influx of new settlers escaping the demolished economy of areas further north (Bacon 1975:24). Settlers from the plantation areas of north Florida and South Georgia saw Central Florida as a new frontier to be tamed, full of new opportunities. This migration brought people like Hugh Partin to the area.

### Watermills

Some of the earliest explorers to America took note of the incredible potential of the water power they observed while looking for suitable settlement areas; this water power would come to drive the watermills that were the central “cog” in American commerce (LaLand 2001:39) and necessary for a successful settlement. Before electricity and steam power were developed, water power was the only way to process resources meant for a market no matter how small or large that market might have been. The importance of these mills can be seen on any map, where the names of long forgotten mills can still be seen as indicators of an area’s

connection to production. Though many might think of Lowell, Massachusetts, when speaking of mills, and equate mills to the burgeoning of the industrial revolution, it was the small community mills that paved the way for growing communities to prosper and become large urban centers (Hasse 1984:280).

### Mills in America

The settlers to Jamestown were more in need of lumber than grist and didn't build their own water-powered grist mill until 1621, which was built by Governor Sir George Yeardley. The first commercial mill in the South was built in 1685 in Virginia by William Byrd, which was 42 years later than John Pearson in Massachusetts in 1643, with the opening of his wool processing mill (Laland 2001:41). Because small community mills or household mills did not have a wide connection to the outside world they are often forgotten and not placed in their proper role within watermill history whereas commercial mills are a part of the narrative of production in America. Historians have not distinguished between merchant and custom mills, assuming that all mills promoted market-type economies (Haase 1984:284).

Community mills of the frontier were the epicenter of a settlement and often took priority over the building of other infrastructure such as schools, churches, and stores (Hunter 1979:3). The mills also gave the millwright a certain prestige within the community, allowing them to rise in influence and often being elected into public offices (Laland 2001:42). Mills influenced more than just industry; they were often the catalyst for other infrastructure such as roads and public policy issues like eminent domain (LaLand 2001:43; Hunter 1979:3). As the population of an area increased, the number of mills quickly followed suit; Louis Hunter (1979:2-3) tracked the number of mills in the mid-nineteenth century United States and found that community mills



numbered in the tens of thousands and, even as the transportation networks such as railroads and canals brought store goods to the far reaches of the country, many still operated.

Though watermills were common in the South before the Civil War (Hasse 1984:285), in the 1860's northern mills were the only ones considered large industry. In the South, mills were small operations providing only for their direct neighbors, except in places like North Carolina where the textile industry has been argued by Bess Beatty (1987:62) to rival that of Lowell, Massachusetts, and Augusta, Georgia, where large-capacity mills provided consumer products for much of the South. In Georgia alone, 311 mills ranging in time between the 18<sup>th</sup> and 20<sup>th</sup> centuries, have been recorded on the Georgia Archaeological Site File, and at least 50 of those were mills powered by a waterwheel (Elliot 2003:59-60). Though most 1860's southern mills may have been small, they were used to provide lumber, grist, and to process cotton for surrounding communities just as the small mills of the North were used for community-based production. Large mill towns in the North were, by the 1860's, fully engaged in industry and the South seemed far behind though documentation seems to suggest otherwise. That is to say that while the South was forgotten as an industrial center, the community mills of the North were also forgotten beyond the Industrial Revolution.

#### Mills in Florida

The minute amount of archaeological documentation on mills in frontier Florida comes from the work of John Phillips (1983) and Brian Rucker (1988) in Pensacola, and William Jones (1981) in Jacksonville. There were many mills spread across the state, some still standing today, such as the Old Spanish Sugar Mill in Deland, Florida, that has been turned into an attraction and restaurant. O'Leno State Park in Alachua county is based around a watermill that worked up

until the twentieth century as a CCC camp and the visitor center has pieces of the mill on display for the general public (Florida State Parks 2016).

Most of the documentation of a mill's existence comes from written historical documents and mentions of mills in newspaper articles or listing on the census. Charles P. Ross (2014) has created a list of mills that were potentially built in Florida based on historical records and some ground surveys. Ross (2014) lists 46 historically documented mills in 15 counties all of varying age, but none the less the list speaks to the volume of research left to do on mills across Florida.

#### Mill Construction Techniques

All wheel-based watermills, large or small, contained some basic elements that are universal despite the location, size, or use. Along a predetermined, appropriate water easement, the millwright would erect a waterwheel on the side of or beneath a structure that would later hold the grinding stones or other fixtures used for production. To bring the water through the mill, a headrace would be constructed running from the mill dam or water source. The headrace would then direct water into the sluice, bringing the water into contact with the wheel. After the water made its way through the sluice, it would exit through the tailrace and be directed back to the larger body of water (Hunter 1979:53-54). The capacity for power of a waterwheel depended on three factors: type, dimensions, and efficient use of the water available. The three types of vertical wheels used in the eastern United States were the undershot, breastshot, and overshot wheels (Figure 7 and 8). Each of these types when built at varying sizes were built for specified or desired rotations per minute. Often the distance the water would fall from the dam or highest point along the river to the mill would determine the type and size of wheel the millwright would build. Pallett (1866:218) describes the need to carefully consider the size of the water wheel

being installed: not only did type of wheel matter but also the proportion of wheel size to water velocity to speed of the work required were fundamental in to increasing efficiency. Undershot wheels would have been the type of wheel predominantly used by small gristmill operations and sawmills looking for quicker rotating motions that larger breast or overshot wheels would not have provided. (Hunter 1979: 61)

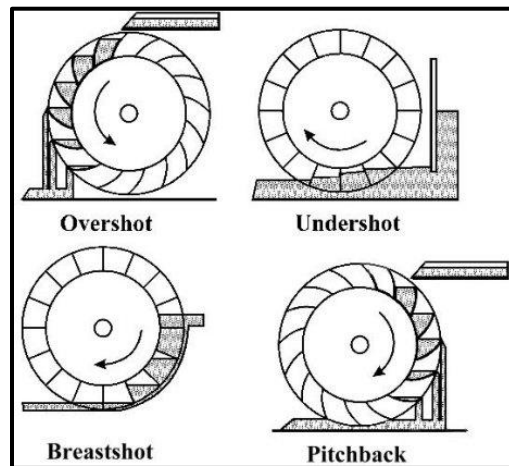

Figure 7. Four types of watermill construction; undershot is the type most commonly found in small community mills with low flowing water sources (Lindsey 1996).

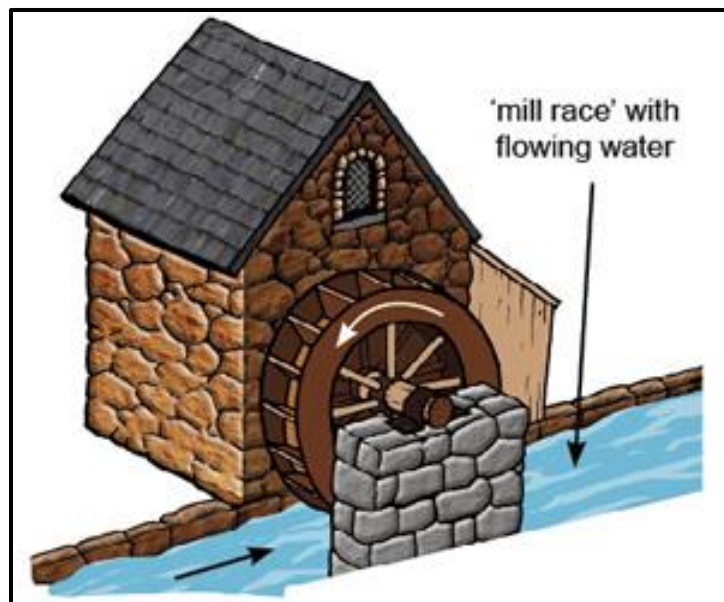

Figure 8. Undershot waterwheel showing water moving through the sluice and the relative location of an associated millhouse (Australian Education Resources).

The undershot wheel is a relatively simple and adaptable (Hunter 1979: 65) type of mill to build and, because it requires very little fall in the water source and works best where there is a consistent amount of water always in motion (Pallett 1866: 228). Based on this information undershot wheels would be ideal for the conditions found across Central Florida due to Florida's consistent and predictable rainfall, and the low head that is found in Florida's waterways that often have little to no elevation change. Henry Pallett (1866:229) states that undershot wheels should only be used where there is "little fall and a great quantity of water." In order for undershot wheels to maximize the power and efficiency by avoiding friction, the headrace should be more of a square shape rather than wide and shallow and the wheel should be slightly narrow. Boards of the wheel are flat and rise perpendicular to the water and never should more than half of each board be underwater in the sluice at a time (Pallett 1866:229).

The mill dam would have been most likely constructed by the millwright from locally available materials including rock-dams, frame dams, and brush or log dams. The best dam to be used for sandy or muddy bottomed streams was the brush or log dam. Log dams were built out of large logs with a sharpened point at the end, these were pile-driven into the soft bottom of the stream with boxes filled with rocks sunk down in front of the logs (Pallett 1866:214) (Figure 9). In north Florida, John Phillips (1998) recorded similarly constructed dams although with some earlier mills using earthen dams. As technology improved and concrete became more widely available, mill dams were constructed of concrete and earth, with the concrete feature laying between the earthen structures; concrete was used in the construction of sluices and building foundations (Phillips 1998:145). Sluices were built into the dam or very near the channel or headrace from the stream, and the building foundations were situated on the dam or on a nearby

hillside (Phillips 1998:145). Though it is not clear if Partin constructed a dam, based on the creek bed and materials available to him it can be presumed that any dam constructed may have resembled a log dam.

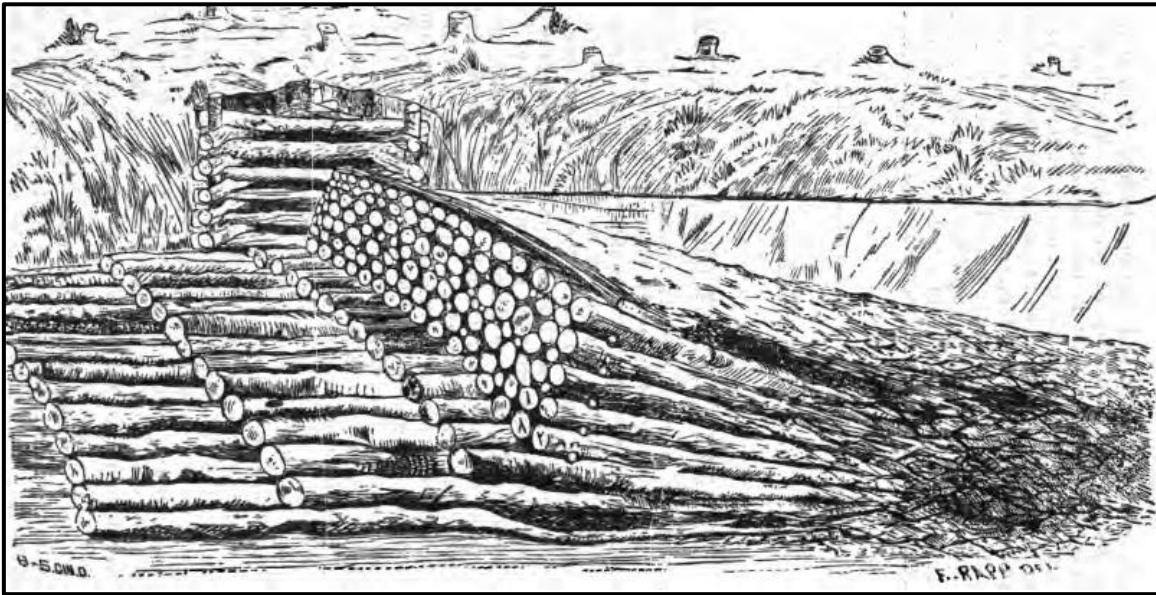

Figure 9. Image of log dam found most often in sandy bottom rivers and creeks. (Leffel 1881:9)

Of the two millwright guides that were available to an 1860's millwright, *The Young Mill-Wright and Millers Guide* (Evans 1795) and *The Millers, Millwrights and Engineer's Guide* (Pallett 1866), neither specify the exact materials that should have been used in the construction of a mill. Both describe, in detail, how to figure out the capacity of a mill and the structural shape that should be used based on available water power. There are tabular guides in the 1866 manual written by Henry Pallett on how many bricks would be needed for a structure of varying size and an entire section on the proper production of steel products, such as axles and gears, to be used in the construction of mills but no plans or instructions on the construction of specific parts. The lack of specific uses for wood, steel, and brick lead me to believe that these materials were likely used although the millwright would have the flexibility to design their own plans for

a mill. Though a millwright may have guides and information on how to build a successful mill, he may have needed some other type of education such as an apprenticeship in order to learn the finer points of running a mill (Pallett 1866:7-8). An assumption could be made that the vagueness of materials needed for mill building is related to the need of millwrights to adapt to the materials that were available to them, and the authors of these manuals may have taken that into account.

### Geography of Mill Areas

Louis Hunter (1979:122) suggests that many early millwrights were unaware of the predictive ways to successfully select a site for a mill, stating they often were working in the dark. I do not think he is giving them enough credit, as they by necessity had to place mills based on some knowledge of the water flow and volume necessary in order to be successful. At the very least, they possessed knowledge of the water flow available in a particular area. I do not think it possible that they were completely unaware of the necessary elements. Basing his opinion on the fact that the millwrights wouldn't have had access, due lack of education or remoteness, to dimensional and temporal data, Hunter (1979) believes that millwrights wouldn't have been able to predict where a long term and successful mill could have been placed.

By first determining the necessary volume of flow and amount of fall that will provide sufficient power, Hunter (1979:115) uses the hydrologic cycle as a framework for effects on potential water energy. Distribution of rainfall, temperature, humidity, evaporation, and air currents are parts of the climate cycle that determine how much runoff will be added to the volume of streams and rivers. They also play a role in how much will stay long enough to add to the volume of flow. Other mitigating factors include vegetation, make up of surface material,

subsurface formations, or the presence of aquifer systems. The human factors that could alter the volume of flow include deforestation, settlement, and cultivation of land (Hunter 1979:146). It should also be noted that natural lakes and ponds, when dammed and gated sufficiently can provide necessary volume of flow for areas with low flow or for mills that need greater volumes of water.

*Table 3. Comparison of rainfall in Florida to that of New England in the late 1800's (Hunter 1979:122)*

	Rainfall	Runoff	Evaporation	Added to Flow
Florida	50-60 inches	20 inches	40-50 inches	10-20 inches
New England	40 inches	20 inches	30-40 inches	< 10 inches

There are several factors that rule out a location's suitability for watermills in Florida and several that place them in contention for a good watermill site. Lack of drop in elevation would be a contrary factor whereas rainfall would be a helping factor. The known sites in northwest Florida detailed by John C. Phillips (1998) were found along river terraces, adjacent to estuaries, and in the uplands. All of these areas have sufficient elevation, appropriate rainfall, though much of the historical data are still unknown, and support regulated flow through surface formations. A comparison in Table 3 of rainfall and water in Florida and New England shows that Florida rainfall was actually similar, and perhaps added more water to the volume of flow than did the rainfall in New England, where mills were more prevalent (Hunter 1979:122). Add in vegetation factors and density of settlement, and Florida becomes an ideal place for water power given the right circumstances.

The St. Johns River basin stretches for 110 miles along the east coast of Florida and, along with the aquifers, provided for a large majority of Central Florida's fresh water and regional transportation in the 1800's (St. Johns River Water Management District [SJRWMD] 2007). Originally the upper St. Johns river basin covered one million acres, of which 400,000 acres were floodplain. The pioneers of the 1800's began implementing flood control features for the purpose of creating water resources for agriculture and transportation canals (SJRWMD 2007). The earliest rainfall data for the Orlando area that is available was compiled by Dr. Winsburg (2003) who recorded that in 1892 Orlando had an annual rainfall of 39.21 inches.

There are several creeks that run to the St. Johns and feed the lakes of Central Florida, many that would have sufficient flow for a mill. Howell Creek, or Howell Branch as it sometimes referred to historically, is a small creek that runs from Lake Winyah near the northern border of Orlando through several lakes finally emptying into Lake Jessup, a major lake along the St. Johns River basin (Figure 10). The creek is completely navigable by kayak and, except for several places where human construction has interfered in its flow, the current is fairly swift, based on personal observation and communication with locals. For the entire 18 miles of its length, the creek is never wider than ten feet. Historic water levels are only available from 1973 and later, though water levels and flow were recorded (Seminole Water Atlas 2016). Between the years of 1972 and 2016 the flow of Howell creek ranged from 6 cubic feet per second (CFS) and 444 CFS as recorded by the Florida Department of Environmental Protection (Figure 11). It averaged 128.5 CFS between the recorded years of 1972 and 2016. Figure 12 shows the flow of Howell Creek from its origin at Lake Winyah to Lake Jessup. Howell Creek, based on the



collected historical data and on modern observations could have and I believe did support a successful mill.

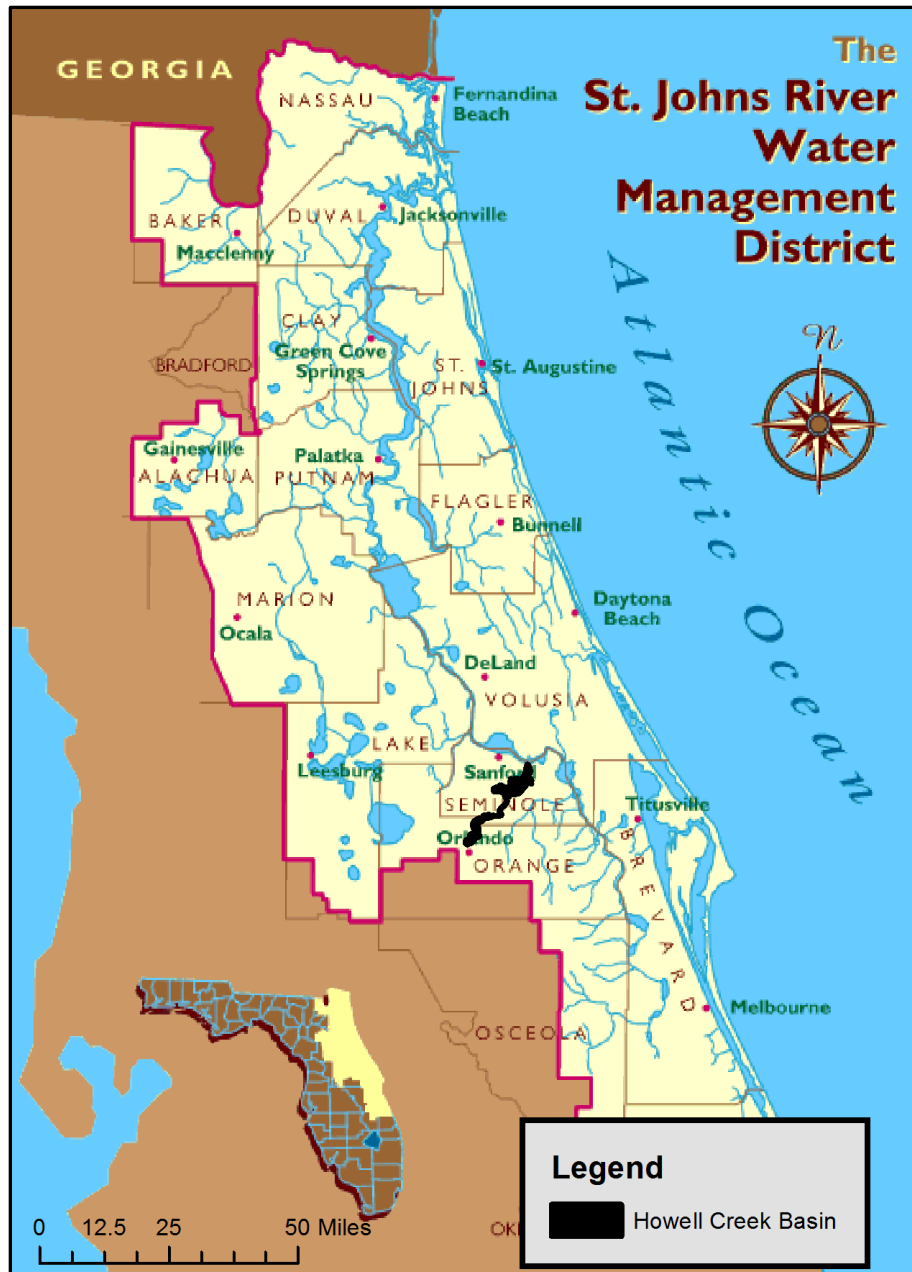

Figure 10. St. Johns river basin (map courtesy of the St. Johns River Water Management District website).

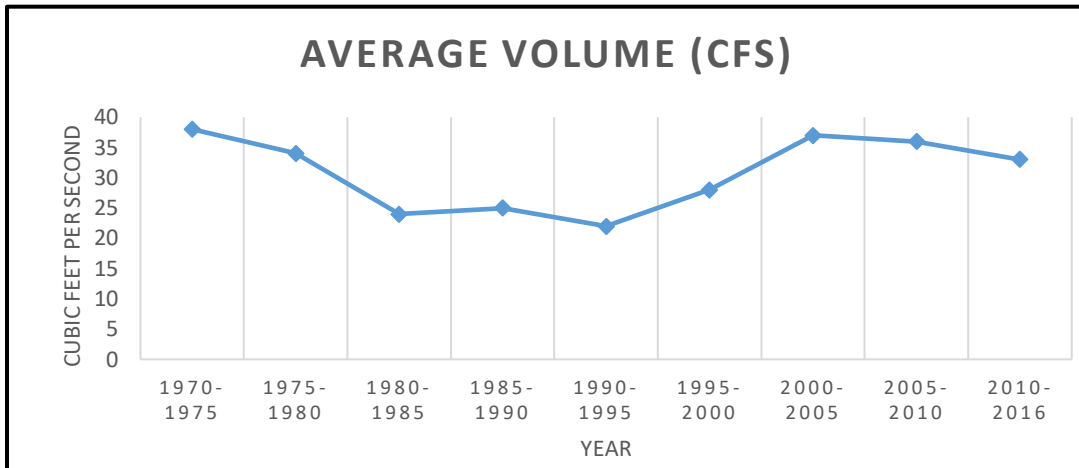

Figure 11. Average volume of water for Howell Creek from 1970 to present. Volume measured in Cubic Feet per Second (CFS) (Seminole Water Atlas 2016).

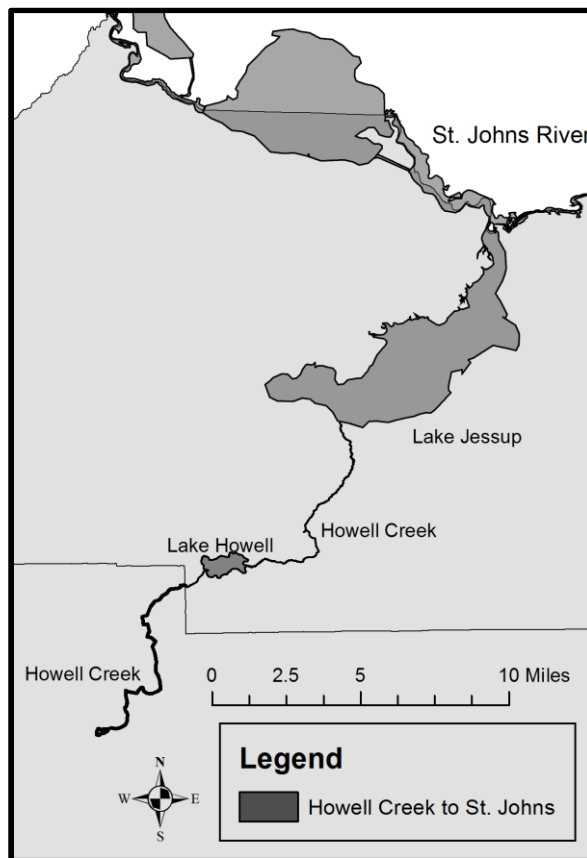

Figure 12. Howell Creek basin from point of origin to the St. Johns river.

### The Partins

Though the environment of Central Florida is one aspect in understanding Hugh Partin and his mill, it is also important to contextualize his past and how that influenced his decisions. Hugh Gilmore Partin was a first-generation American born to Irish immigrants in 1806. Partin's father, Charles Partin, had immigrated in the late 1700's with his brothers, and while his brothers stayed in South Carolina where they had arrived, Charles moved south to Tattnall County, Georgia. Hugh Gilmore Partin was born in Reidsville, GA, the day after Christmas and married in 1835. By 1847 he was travelling to Florida on foot looking for a place to homestead with his growing family. Being a millwright, he most likely was looking for a community in need of a mill and sufficient water power potential. He spent most of his time in what is now Central Florida, and returned to Georgia with a plan to move. His family set out for Florida and the Jacksonville area in 1853, eventually settling along the St. Mary's River (Robinson, 2002). As they moved south along the shore, the Partin family spent some time in Sanderson, Florida, after which they made a trip back to the family farm in Georgia, before finally reaching Central Florida in January of 1866 (Figure 13). Partin, along with his family of ten and a slave family of four (it is not noted historically whether the family stayed after emancipation, though there are unmarked graves in the family cemetery that may be connected to this family), crossed the St. Johns river by ferry where it emerges from Lake Harney (Hetherington 1980).

Though Partin owned several slaves and two of his sons served in the Confederacy, there is no documentation about his position on the war or whether or not he did anything to support the war effort. It should be noted that Orange County was the only county in Florida to vote against secession.

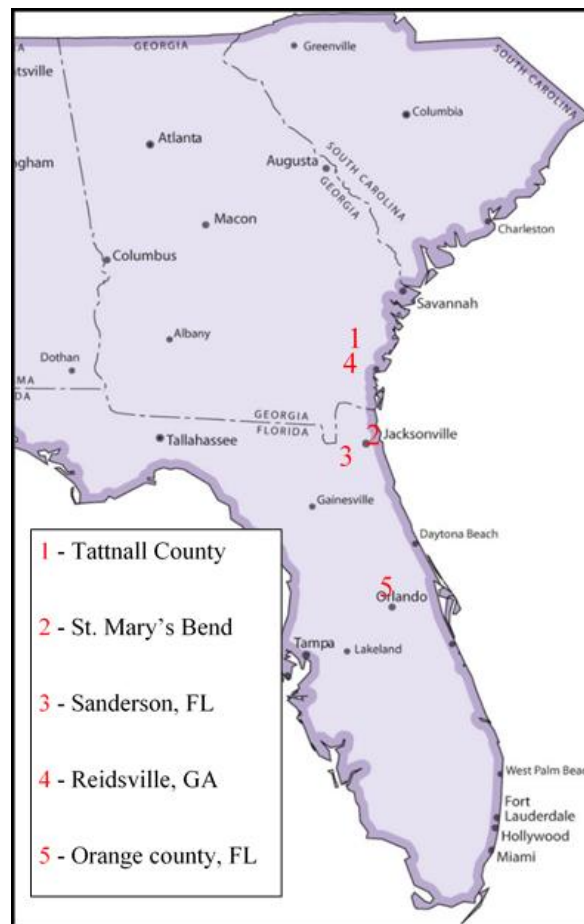

Figure 13. Partin family's stops on their way to Orange county Florida numbered in order of arrival, the family started in Tattnnal where Partin was raised then moved to St. Mary's bend, Sanderson, FL, back to Georgia for a short period of time, and finally settles in Central Florida.

The family spent the first part of the year in a log cabin along Lake Conway, an area that had been settled by William Harrison Holden. Holden was a recent immigrant, in addition to a newcomer to the area in 1865, having originally moved to Florida in 1843 from southern Georgia (Bacon 1975:25). He married Nancy Mizell, a daughter of David Mizell Jr., and bought 1200 acres near what is now known as Lake Holden, where he intended to go into the cattle business (MacDowell 1950:11). Thieves and rustlers stole his cattle and, in an attempt to prevent the theft, Holden erected fences, angering other cattlemen. He turned to citrus instead (Bacon 1975:25). Holden eventually reached commercial success when out of the hundred acres of

orange trees he dedicated five to grapefruit and is credited with starting the commercial growing of grapefruit in Central Florida. He used commercial steamers out of Mellonville (now Sanford) to send his product north to Charleston, South Carolina (Bacon 1975:37).

In 1866, Holden, along with his brother-in-law John R. Mizell, a local judge, invested in the construction of a mill for the purpose of ginning the increasing amount of cotton that was being produced in the area (MacDowell 1950:11). They employed Partin, an expert millwright to build a saw, grist, and gin mill on forty acres that Mizell had obtained through the Internal Improvement Fund, a federal land grant to encourage settlement in frontier areas available to homesteaders at the time (Blackman 1927:87). The Holden/Mizell mill, as the history books call it, was built in 1866 and would come to serve the community as a combined grist (cornmeal), lumber, and cotton processing center for the region now known as Seminole and Orange Counties, and as the seat of influence for the Partin family settlement. Partin began to build a homestead for himself and his family on the surrounding acreage while running the mill. Beginning with a log cabin, two years later Partin built a house less than a half mile from the mill (Adams 2007:53). Partin would eventually become influential in the county by serving on the County Commission and participating in other infrastructure projects like roads (Bacon 1975:45) until his death in 1878. Though the location of the mill is still visible when the vegetation is cut back and the water low, and the family cemetery plot is still in its original location, the location of these features had been unknown except for a few members of the Partin family.

The histories of Hugh Partin and Florida are interconnected and have now been laid out in the context of industry and water power. The Florida that Partin entered was on the verge of growth just before the Civil War, though because of blockades and supplies being needed by the

armies, it was economically set back during the 1860's and 70's. It can be presumed that Partin was moving in order to escape worse economic conditions in Georgia, and in the process made his mark on Central Florida. In the next chapter, I will detail how I was able to locate the watermill he built to ensure his success in Florida.

## **CHAPTER THREE: FINDING THE MILL**

Geographical Information Systems or GIS, a spatial analysis tool that uses maps to represent spatial information, has given archaeologists a more efficient and accurate tool to analyze the spatial information collected about sites and to conceptualize the past human experience (Rennell 2012:510). The flexibility of the program has enabled researchers to not only analyze information collected in the field but to also build models of sites before excavations begin. For this project, I used ArcGIS a program that was provided to UCF through ESRI, for both predictive model-building and as a means to represent spatial information collected during fieldwork. The GIS shapefiles and data that I created were also meant to meet the requirement of a permit obtained from the Florida Division of Historical Resources (Permit No. 1617.001, Appendix A). This requirement ensures that data will be made available to future researchers.

### GIS

Two factors of this project made the creation of a predictive GIS model a necessity: a lack of historic documentation and urbanization of the area. First, a map of the mill location did not exist and consequently the exact location of the mill was unknown. The aerial maps of the area, that were taken during the 1940's and 1950's, that traditionally would have been used to locate mill features were difficult to analyze due to ground cover and modern disturbances. Second, the surrounding community has grown rapidly since the mill was built and modern urbanization has encroached on and destroyed many historic sites, it was unclear before the mill was located how much, if any, of the mill would be visible.

The GIS portion of this research was done in two phases, one before fieldwork was complete and the second afterwards. These phases used GIS in two different modes: modeling and site map building. The modeling proved very effective in locating the mill and made an effort to ground truth the area much easier and efficient. The site map created after the fieldwork provided a very accurate map with high manipulability, and allowed for the data collected to be made into shapefiles and can now be shared for future researchers of mills or of industry in Central Florida.

#### Predictive Model

Though historic written records and several newspaper articles focusing on the Partin family history showed the mill was built somewhere in the Howell creek area (MacDowell 1950:1; Robinson 2002) and that Hugh Partin lived in Central Florida around the time of the mill's existence (United States Census [USC] 1870; see Figure 2), there was no documentation about the precise location of the mill. Given that many of the waterways around Central Florida are difficult to navigate due to lack of access points and swampy conditions as well as the sheer number of potential areas even when narrowed to Howell Creek, a better option for locating the mill had to be created. Using GIS and other available information a model, that can be used in the future to find and possibly predict where other mill sites may be located, was created in order to narrow down the number of potential waterways that the mill could have been located on. The model was also built with the intention that it could potentially locate other mill sites that could be used in future research on mills in Central Florida and industry in Florida. To give the model context, an 1890's survey map was georeferenced and used as the base map in order to see parcels and waterways of Central Florida in the nineteenth century. The base map was obtained



from the RICHES program (Regional Initiative for Collecting the History, Experiences and Stories of Central Florida [RICHES of Central Florida] 2011) as a digital image file and was georeferenced using the visible county borders on the scanned map that lined up with modern county border shapefiles (Florida Geographic Data Library [FGDL] 2016).

When deciding the parameters of the model, several factors were taken into account: ownership of the land, availability of water power, and proximity to historic infrastructure. Ownership is an important factor when looking through historical land records in an attempt to find the location of the mill; the only description of the mill found was a reference to a Holden/Mizell mill and the millwright those men hired by the name of Hugh Partin. These names were the only concrete connections to the mill. Though that information lacked much detail, it was by far the easiest aspect of the data to collect and then analyze. The Orange County Comptroller's website has maintained a very accurate record of parcel ownership, and has an easy-to-use search feature on their website (Orange County Comptroller [OCC] 2016). I conducted a preliminary search of the three-main people (Partin, Mizell, and Holden) involved in the construction and funding of the mill. I then sorted the results by year of ownership, using 1866 as the main reference year but I noted ownership into the 1890's. Orange County and Seminole County property appraisers both make available to the public GIS data files containing all of the parcels within their boundaries (Orange County Property Appraisers [OCPA] 2016; Seminole County Property Appraisers [SCPA] 2016). After downloading the section/township/range data files, I manipulated the shapefiles by using the parcel identification numbers I obtained through the deeds found on the comptroller's site. I used the select by attribute feature in ArcGIS to create a layer of selected parcels, comprised of the parcels owned

by the three men, creating three different shape files that could then be overlaid on a base map of Central Florida (Figure 14).

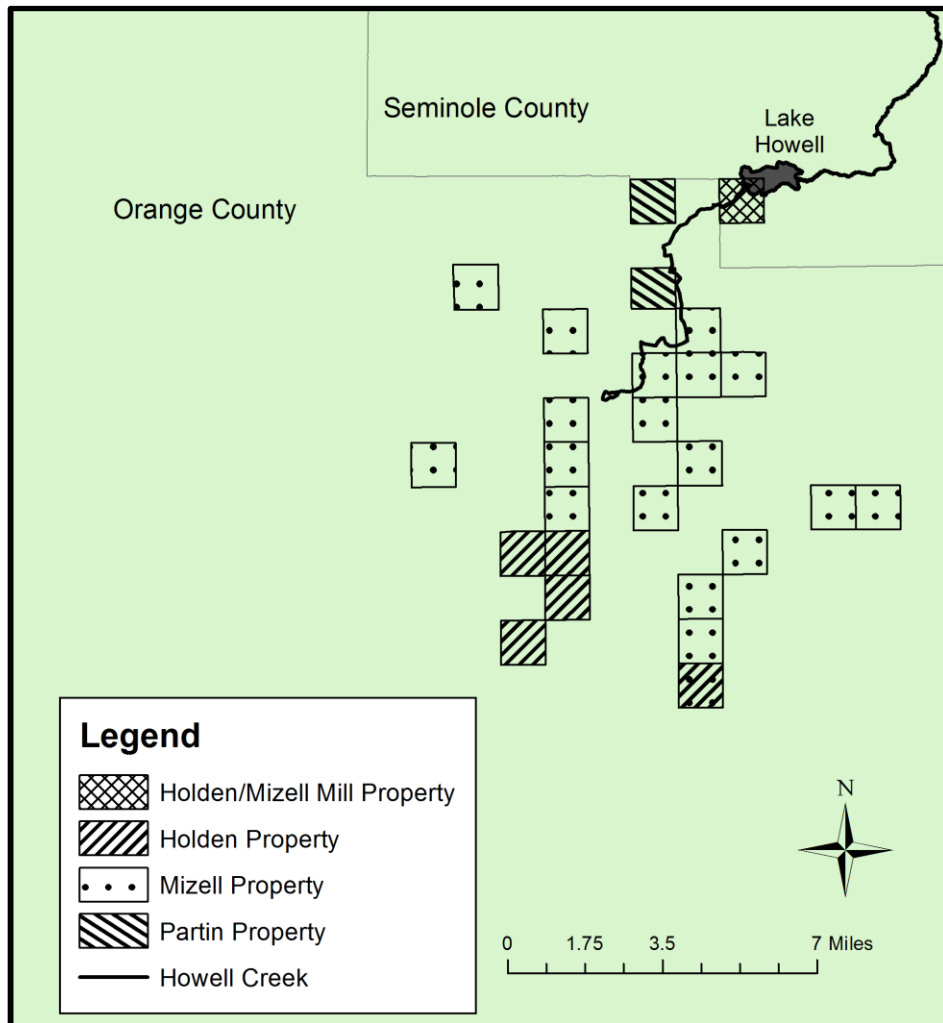

Figure 14. One layer of the model that shows the property ownership of the three men, in relation to Howell Creek.

It has been documented that most mills are located within a fifteen-mile radius of available infrastructure (Hunter 1979:15) such as train stations and navigable rivers. Once the parcels were narrowed down to having been owned by one of the three men and containing a running water source the clipping tool was used to define a fifteen-mile radius around the center of Orlando based on the 1890's historic map that I used for the base map (Figure 15). The center

of Orlando was used due to it being the seat of the combined county at the time and the only town center that would have been available to a settler moving to 1866 Central Florida.

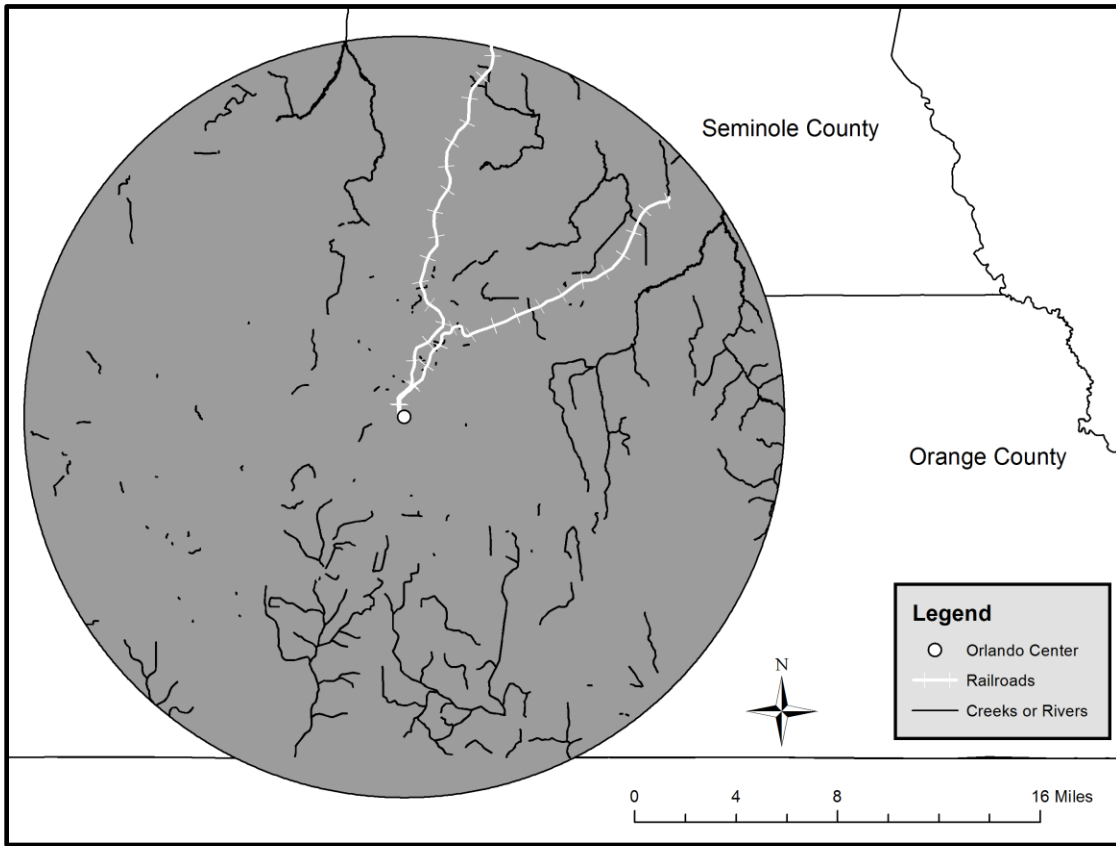

Figure 15. Fifteen-mile radius around modern City of Orlando and hydrology information and historic railroad locations.

With the parcels that were owned by each man in place, I created a hydrology layer, using data from the FGDL website (FGDL 2016) (Figure 15). Since lakes are out of the scope of this particular model, another select by attributes was conducted in an attempt to select only creeks and rivers covering both Seminole and Orange counties. A separate data layer was created with this selection and placed on the same base map as the ownership parcels. From there, areas of single-person or multiple-person ownership that had no water resources were eliminated from the model (Figure 16).

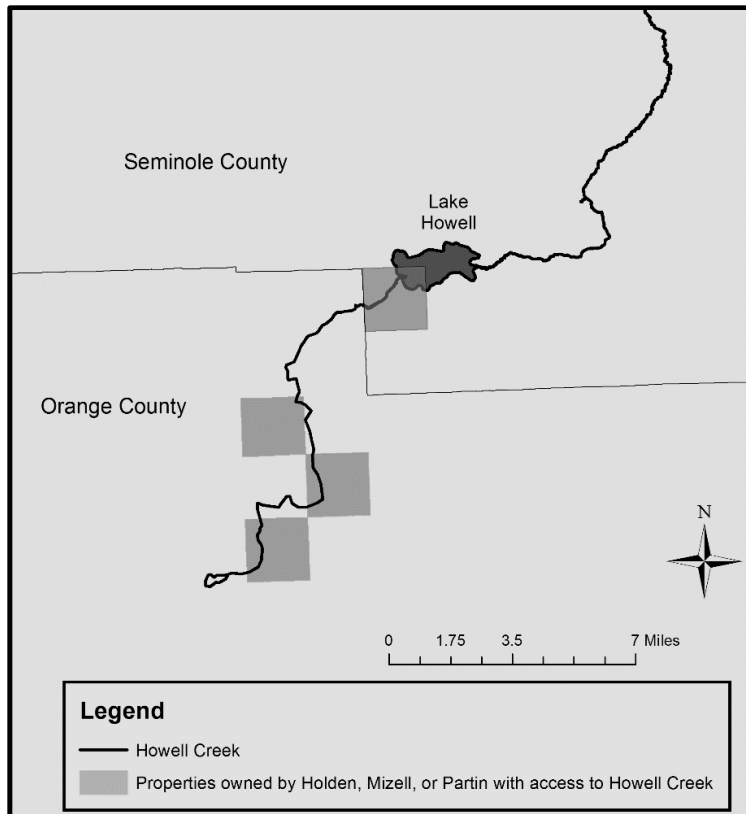

Figure 16. Properties with access to Howell Creek.

When I completed the final map, only one parcel met all three requirements: combined ownership between Holden/Mizell/Partin, an available water source, and accessibility to infrastructure. The predictive model revealed a section that rests on the modern border between Orange and Seminole counties, Howell Creek runs through it towards Lake Howell, and between 1866 and 1890 all of the men owned it at one time or another (Figure 16 and 17). Not only did this predictive model lead me to potential sites, it also led to further information about the mill and Hugh Partin. As part of the ground-truthing effort, areas around the 64 acre section outlined in the model were surveyed by foot and car. These efforts revealed a cemetery associated with the Partin family, and connections to information they had about the mill and Hugh Partin. The survey also revealed features such as a modern dam that is just upstream from the mill

foundation. Chapter 4 will discuss the steps taken during after the ground-truthing and how the site was located.

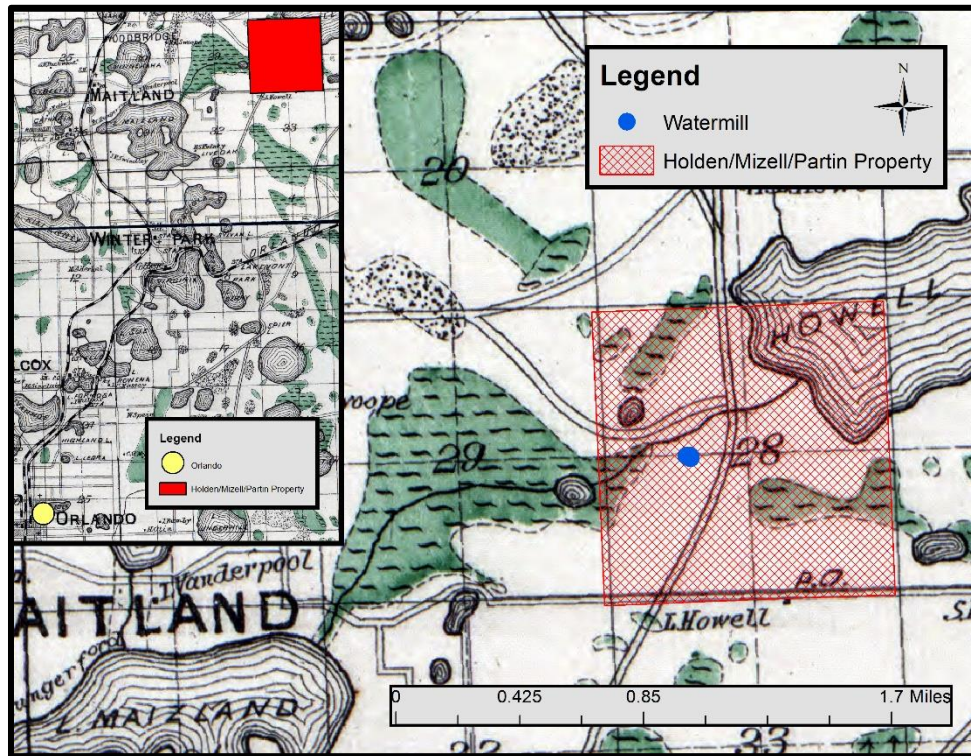

Figure 17. Final map built using the predictive model. Four properties were shown to have sufficient water available, but only one had the ownership history to support the historic record. (1890 survey map pointed out to me by Dr. Lester and downloaded from the UCF RICHES archive [RICHES of Central Florida 2011])

### Mapping

GIS proved useful in locating the mill with a model, and it was useful in analyzing the site itself through data collected during the fieldwork portion of the project. The main focus of the mapping of the mill was on documenting the location of the mill, its features, and any material remains that were recovered. This information was then used to create GIS data frames and layers so that they could then be shared with researchers in the future.

A reference datum was set up using the Trimble GPS, and a permanent stake was placed on the north bank of the creek becoming *datum01* and a back-sight point was setup on a railroad

tie just north of *datum01*. These would be used daily during surveying in order to maintain a static geographic location and were located on the north shore of the creek to minimize transportation of sensitive equipment across the creek. The north shore of the creek is also a much higher elevation, protecting the datums from high water and providing a clear view of the mill site. Mapping began by taking points of the exposed mill feature, a bottom point was taken as well as a top point of each corner. A total of 32 points were taken of the mill to ensure the greatest detail possible when made into a shapefile. The shapefile was then used to place the mill on a site map. After the mill was surveyed, a survey of the debris field in the creek was completed. Though there were a great deal of brick and concrete debris, a focus was put on the overall size of the debris field and items of particular significance. Points were taken on what were obviously bricks with a maker's mark and bricks that matched the overall texture, look, and feel of those with a maker's mark (Figure 18). Concrete block was largely left out of the survey except for large pieces that could potentially be a part of a presumed wall that extended into the creek.

A Topcon GTS 235 total station with data collector were used to shoot in the coordinates of the units that were excavated. These points would later be included in the overall site map and would serve as reference points for the units if any material remains were found. During the excavation process, the total station was kept on hand in order to continue documenting any finds and to keep data collection methods consistent. As we excavated, a total of three features were documented using the total station and each were made into shapefiles and used in analysis of the site (Figure 18).

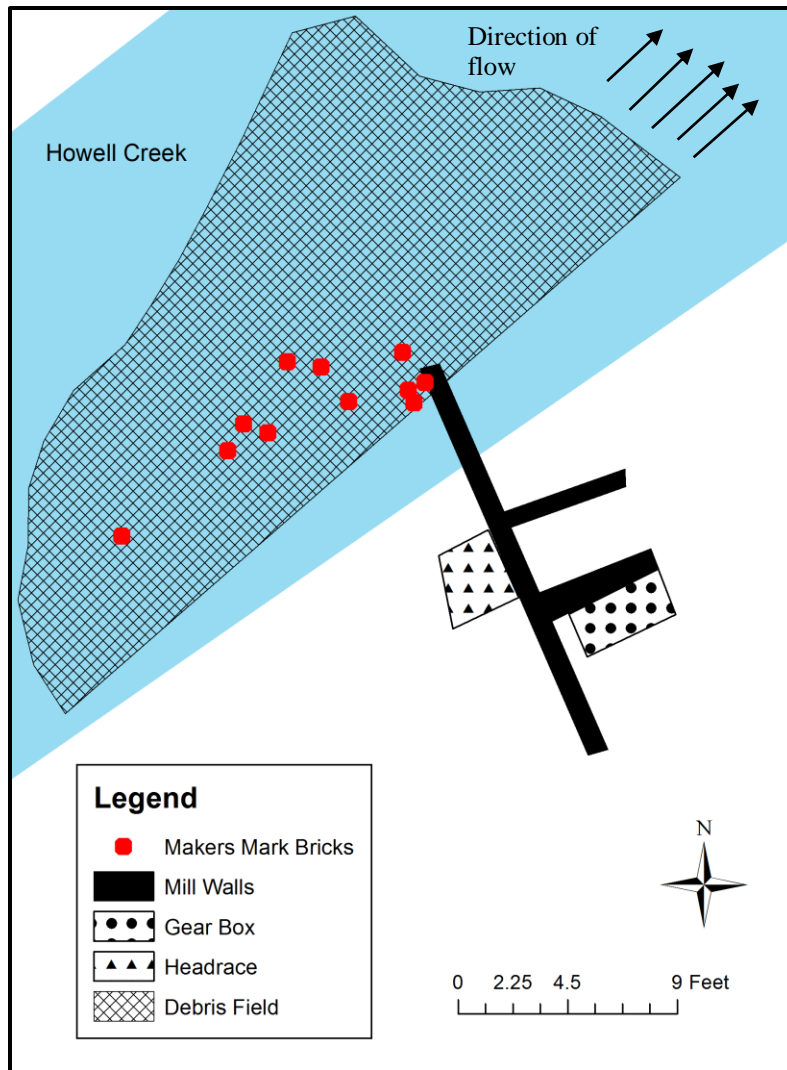

Figure 18. Layout of features recorded before excavation.

All of the points that were obtained were placed into an Excel spreadsheet and using ArcGIS shapefiles were created using the coordinate system WGS 1984 UTM Zone 17N, this was used throughout the project for all projections. Three layers were projected using these shapefiles: the visual mill feature, the debris field and makers mark bricks, and the excavation units. These layers could then be placed on base maps and analyzed individually or as a whole.

A total number of material remains recovered, depth of the excavation units, information about the soil, and general notes about the site were included in the attribute table of the map.

Though the mill was located and could now be recorded, the existing foundation only revealed the location of a mill. The exposed foundation could only reveal basic information of size and basic construction, further information such as original construction material and type of production use would need to be determined using excavation methods. Chapter 4 will discuss the methods used to excavate the located mill foundation, the mill as found was in bad repair and appeared to have some modern features.



## **CHAPTER FOUR: ARCHAEOLOGY OF THE MILL**

In order to answer the research question of how the mill was built and designed to be used for production of goods for the community, archaeological field methods were used to meet specific objectives related to the mill itself. The size of the original mill and mill house, construction methods used, and the capacity of the mill operation were all questions that could be answered through work in the field. Fieldwork was broken into two phases of work, a Phase I pedestrian survey of the creek bed and a Phase II excavation of the area around the mill. The two phases were completed sequentially, the mill had to be located and had not been studied or documented previously so it was important to collect spatial data on the existing area before fieldwork began to ensure correct information for the master site file.

### Phase I: Pedestrian Survey

Before any excavations could begin, a pedestrian survey needed to be completed of the area where the mill was known to be located. In the spring of 2016, a survey of the creek was conducted, beginning at the mill and concentrating on a debris field of construction material located directly adjacent to the mill. The intention of the creek survey was to locate any associated mill features such as a dam or buildings. The survey was continued downstream approximately 62 meters, under the modern Howell Lane bridge that now exists over the creek. Often evidence of a lumber mill can be found by walking upstream towards a mill location, in the form of cut lumber that had been abandoned in the creek bed (John Phillips, personal communication 2015). After surveying the downstream area, I walked upstream past the mill and as far southeast as the modern dam, a distance of 125 meters away that exists just west of the Lake Howell Road bridge (Figure 19).

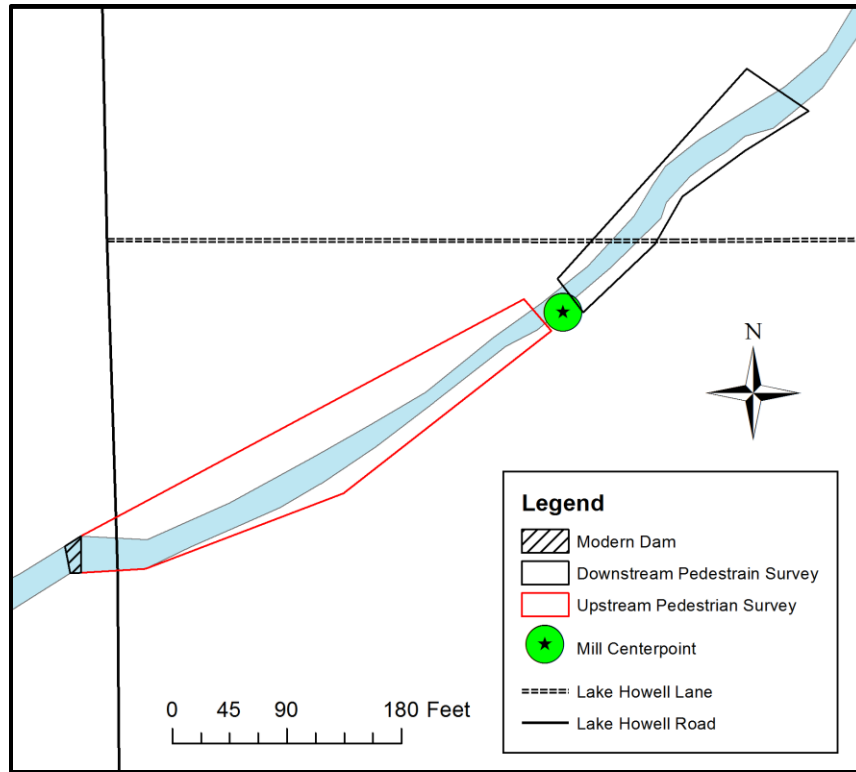

Figure 19. Pedestrian survey areas upstream and downstream from the mill.

Where the mill now exists, there is a 5m x 3m area of debris that can be seen under the water. The debris field stretches across the creek towards the north bank. Given the low level of the creek it is possible to wade into the water and clearly see the debris. The debris field is a mixture of modern refuse along with concrete block and brick construction material. The items that were readily visible were counted and categorized based on material and approximate age (Table 4). Any items in the creek that were found to have cultural significance were photographed in situ, a point was taken with the total station, and items were then collected out of the creek if possible. The focus of this project was the existing mill foundation and areas to the south on the shore side of the mill, so a full excavation of items under the water was not completed. The existing foundation appears to be a modern type of masonry concrete

confounding an exact date for the mill. A complete understanding of the age and origin of all of the items cataloged in the survey of the creek will not be definitive until future work can be completed in regards to the history of concrete and its variable use throughout the nineteenth century, which will be discussed further in Chapter 6.

*Table 4. Count of construction material found in debris area located in the creek, upstream and downstream are delineated by the mill itself.*

Construction Material	Location	Pieces	Total
Concrete	Upstream	72	201
	Downstream	129	
Red Brick	Upstream	22	57
	Downstream	35	
Yellow Brick	Upstream	2	5
	Downstream	5	
Makers Mark Brick	Upstream	10	10
	Downstream	0	

From the debris field and moving northeast downstream (See also Figure 19), the water becomes substantially shallower and only modern refuse could be observed. The survey of this area was intended to find any remaining cut boards that would substantiate the claim that the mill was for lumber production. Finding an intact board could speak to the size of lumber the mill would have been able to mill and possibly the volume of lumber that could have been produced. No boards were found despite a family member stating that in the past one had been recovered (Diana Niedermann, personal communication 2015). The survey of the area upstream from the mill found the water deeper and mill-related items were less numerable. The debris in fact was

found to have a definitive boundary upstream of the mill, the creek turned into a sandy bottomed creek once beyond this line (See also Figure 18).

During the pedestrian survey a total station was used to record points on the mill. This data would later be used to determine the approximate size of the mill during its time of operation. In Chapter 5 the measurements of the sluice area, where an axle is still intact, will be used to determine the size of the wheel that was used. From those measurements, a mathematical formula will be used to determine the potential volume of water the mill was designed to handle and the probable power output of the mill outlined in Chapter 6.

#### Phase II: Shovel Tests and Trenches

The direct questions about the mill's size and construction needed to be answered using methods beyond a pedestrian survey. Because modern concrete block is the construction method that can readily be seen and modern refuse litters the creek shoreline, excavations around the mill and the shoreline to the south were able to expose more historic features. Two grids of shovel tests were placed to the southwest and southeast of the mill while two trenches were placed next to the mill. Before excavation began, the units were set out by the crew and natural debris was removed when possible. Given the high number of cypress tree roots in the area, laying out units in precise dimensions proved difficult. Each crew member was given a notebook to record data and observations; they were also responsible for filling out forms (Appendix B) in relation to the unit they were working. Photographs, maps (Appendix C), and drawings were all completed by the crew for each of their individual units.

The shovel test grids were laid out directly south of the mill. The location of these units was influenced by the location of cypress tree roots and where potential remains would be found.

For example, the area around the headrace that has been flooded and deluged with water over the last century was not shovel tested. Because of this water disturbance the areas tested were mostly to the south of the mill and to the southeast of the headrace wall. The shovel tests were intended to determine the extent of the wheelhouse and find any other structures that may have been associated with the mill. The secondary purpose of the shovel tests was to recover any material remains.

In order to survey the disturbed area of shoreline to the southwest of the mill shovel tests were placed in areas that both lined up with the mill and allowed for maximum surveying. The disruptive growth pattern of cypress roots made a grid pattern of shovel tests nearly impossible. Each shovel test measured 50cm x 50cm and soil was removed using square shovels, 10cm at a time following a prescribed arbitrary level. Material was screened through 5mm screen, and items that were determined to be of interest were bagged and documented on the shovel test form (Appendix B). A total of eight shovel tests were completed in all; see Figure 18 for a complete plan view of the site.

The two trenches were laid out based on the size of the mill and the area that was of concern. Trench TR01 was laid parallel with the western wall or PMF07 of the mill and ran over the head race (Figure 20). TR01 was broken into three sections A, B, and C which were all 1m x 1m units (Figure 21). It ran the entirety of the wall, the north barrier being the creek and the south barrier being the shovel tests. This trench was intended to determine the construction materials used, and the boundaries of the head race. Recovery methods included shovel shaving and removal of material with a trowel. Levels were removed using prescribed arbitrary levels (10cm), and screened through 5mm screen. The use of natural stratigraphy was made difficult

by the high water table and a lack of diversity in the soil matrix. Items of interest were bagged for curation and analysis. Trench01 unit C was only excavated down to the second level, because of the severe disturbance of the area and a lack of material recovered. Trench01 unit B, was split into two 50 x 50 cm units and the one closest to the existing wall was excavated (maps in Appendix C).

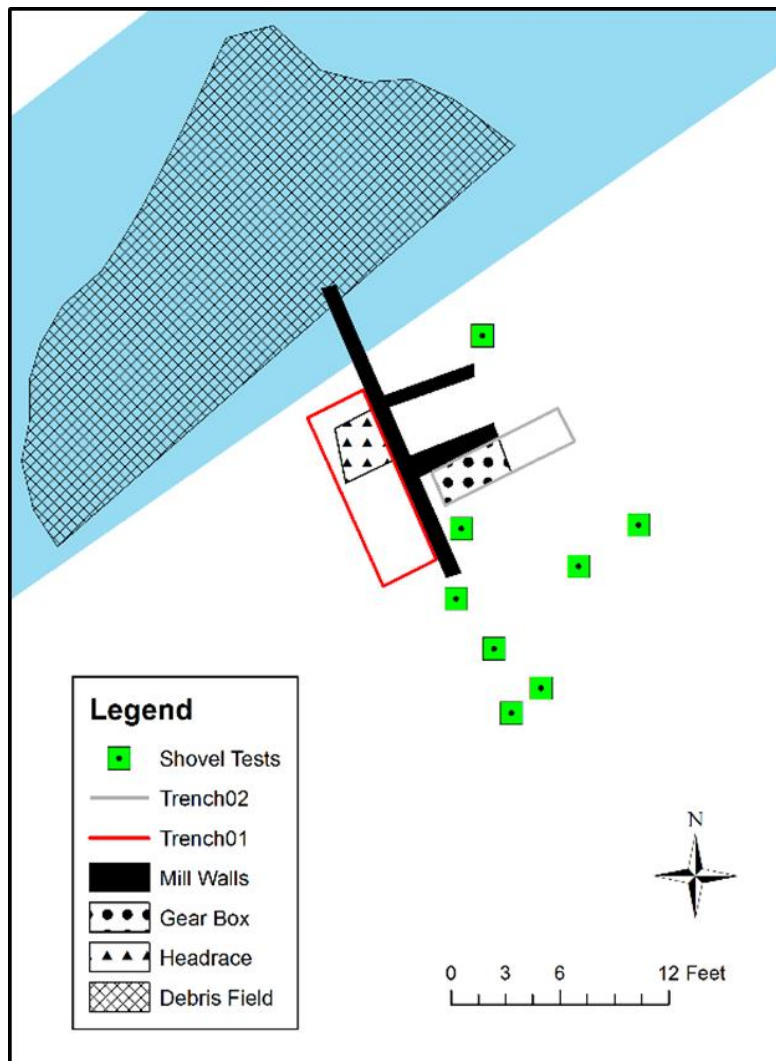

Figure 20. Planview of mill site, trenches and shovel tests are shown.



Figure 21. Trench01, with labeled sections.



Figure 22. Trench02, with labeled sections.

Trench TR02 was laid perpendicular to the back wall, with its western barrier being the headrace wall. It included the gear box and ended at the end of the exposed tail race (Figure 22). TR02 was also broken into two separate sections, A and B, section TR02A being the gear box and TR02B being the remaining 50cm x 1m unit of TR02. This trench was intended to determine if any material remains could be found in the gear box and to find the extent of the tail race. Recovery methods included shovel shaving and removal of material with a trowel. Levels were removed using natural stratigraphy, placed into buckets and screened through 5mm screen. Items of interest were bagged for analysis and curation.

During phase I, detailed spatial data of the mill and surrounding areas were documented, this information was used to create maps to aid in analysis of the mill site and will be made available for future research. Phase II was successful in allowing for more detailed information to be collected on the mill's construction and design. Though there were not a large number of artifacts collected for curation, the information collected in this phase will be used in the next chapter to analyze the design of the mill. The artifacts that were collected will be used to date the remains of the mill, since it does appear to have several temporal periods of construction present.



## CHAPTER FIVE: RESULTS

In this chapter, the excavation of the mill will be reviewed with an in-depth analysis of each artifact collected and the context in which it was found. This chapter will focus solely on the field work and methods used to excavate. As each unit was excavated, features were designated by the prefix Partin Mill Feature (PMF) and the sequence in which it was identified. Each artifact was also designated by Partin 2016 Mill (P16M) and a number designating the unit it was associated with and a lot number, in order to meet the requirements of the Florida permit. Further information about the information collected and the diagnostic nature of the material recovered will be discussed further in Chapter 6.

### Results

All of the recovered artifacts were collected during a week-long effort to complete the necessary excavations for the fieldwork aspect of this project while the pedestrian survey and subsequent Phase I survey with the GPS and Total Station equipment was completed over an extended period of time. The excavation needed to be completed during a week-long period due to faculty availability and seasonal weather concerns. In order to meet this timeline, members of the UCF anthropology undergraduate organization, Hominids Anonymous, volunteered to assist with excavations. The following information on the artifacts recovered during the excavations of the trenches and shovel tests are a combination of lab analysis, my own notes and observations, and material from the field crew notebooks.

Visible features of the mill were used as demarcating points for the excavations. The mill foundation that is visible is located on the shoreline to the south of the creek. In drier periods the mill stands several feet above the water line, but during the wet season it is only inches and parts

of a wall are under water. The sluice and existing axle are visible; the sluice was inundated with water during excavations as the floor of it sits much lower than the rest of the mill. This feature, which is common of undershot wheels, will be discussed in the following chapter. The walls of the sluice are leaning and are in obvious disrepair. The sluice walls are identified by the feature name PMF05 for the south wall and PMF06 for the north wall (Figure 23). Running perpendicular to the sluice walls is a central wall identified as PMF07 (see also Figure 23), this wall contains the opening for the head race and also the most visible aspects of the modern masonry units, also visible in this wall are metal rods protruding from the mortar surrounding the blocks (Figure 24). Parallel with the sluice walls is the gear box that is section A of trench02 and was given its own designator of PMF02. PMF02 measures .57 m x 1.8 m and has protruding over it the axle fitting for a gear (Figure 25). All features can be seen in figure 26 along with their designations.



*Figure 23. Existing mill foundation, walls are labeled with their feature numbers.*



Figure 24. Visible metal reinforcement in concrete block on feature PMF07.



Figure 25. Portion of axle that protrudes over gear box and contains the attachment points for a potential gear.

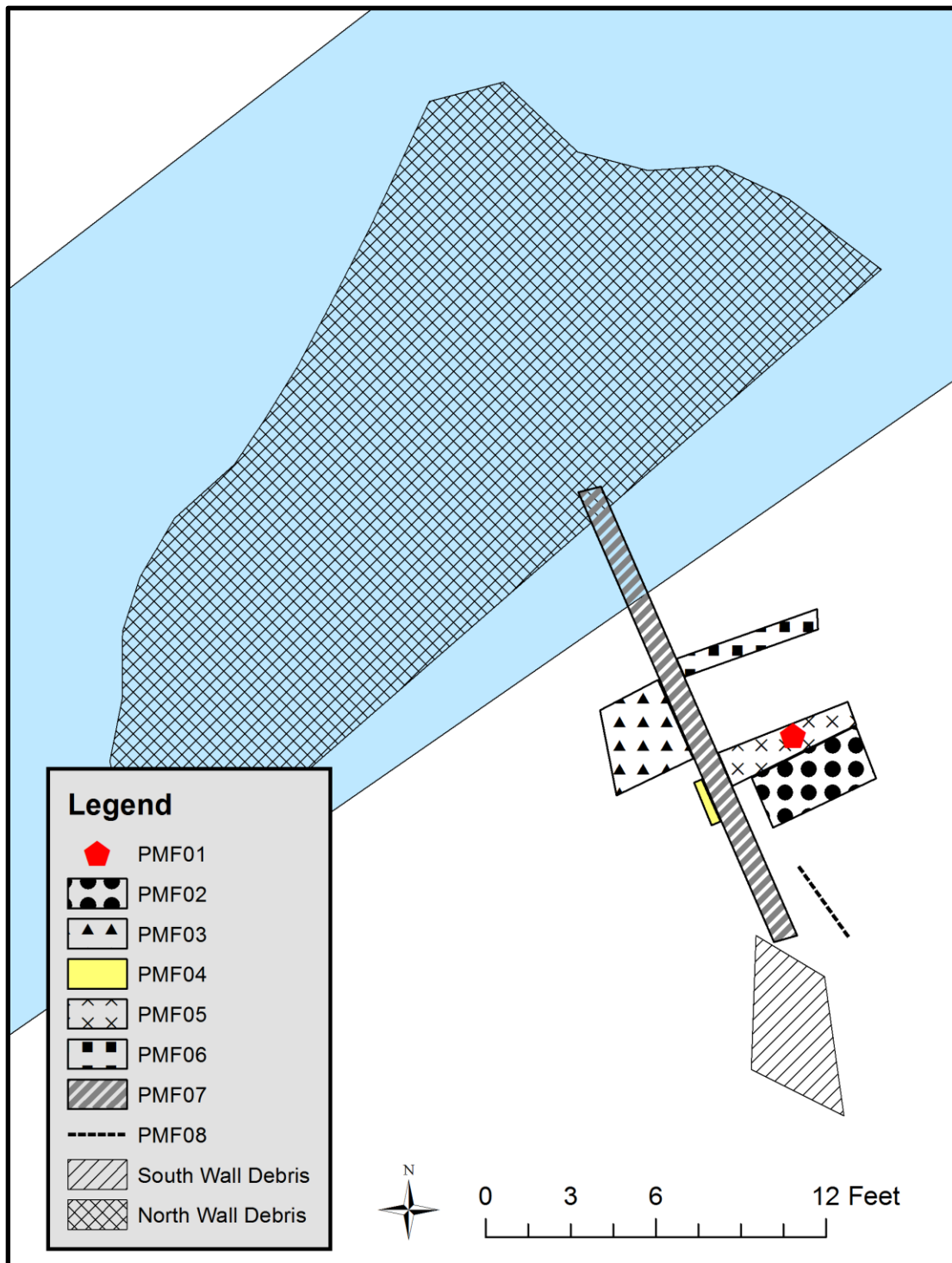

Figure 26. Map of all features recorded at mill site. Wall debris areas were not designated as features.

## Trench01

Trench01 was laid out with the intention of revealing the extent of the headrace (PMF03) and PMF07 as well as exposing original construction material left from the building of the mill (Figure 27). The trench was laid out into three sections with trench01A containing the portion of the head race that was visible (Figure 28). Trench01B and trench01C were intended to capture, if possible, the rest of the concrete wall that included the headrace. Work on trench01C was abandoned after level 1 did not reveal any significant information and further digging to reveal the extent of the wall was virtually impossible due to cypress knee incursion. Focus was then moved to trench01B and trench01A, which proved more viable.



Figure 27. Profile view of trench01 showing new construction on top of older construction. Headrace is visible in center of picture.

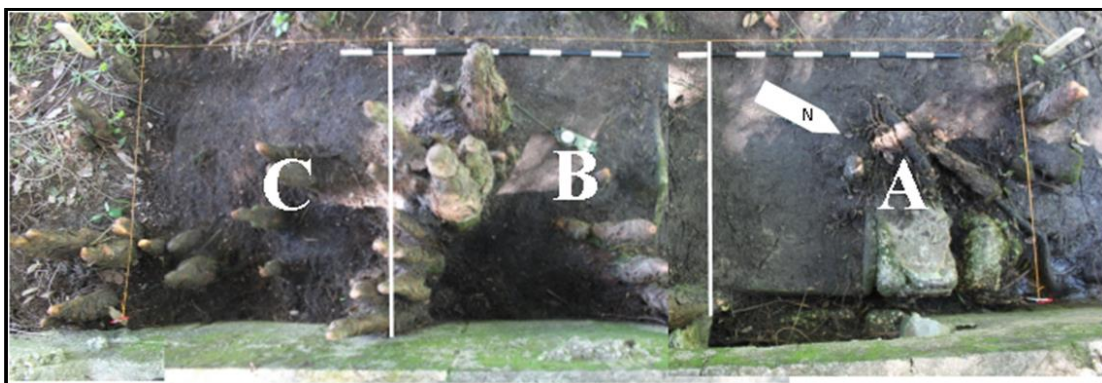

Figure 28. Plan view of trench01, with sections labeled.

Trench01B was excavated in two phases; soil removed from level 1 did not reveal much in the way of construction material, though level 2 is where the material recovered was located.

Because the area nearest PMF07 within this section was relatively clear of cypress knees, efforts concentrated on this portion of the unit in an effort to excavate down to the bottom of the wall. After removing two levels of soil, a change in construction material was revealed, the exposed masonry blocks appeared modern but 20 cm down it appears that the masonry blocks were placed on top of poured concrete. A wooden frame is visible (Figure 29) and extends 2 cm from PMF07, this was designated PMF04. The concrete material that fills the gap between the wall and the wood frame is comprised of what appears to consist of small white stone aggregate. Similar material was recovered in the excavation of trench01A and will be discussed further later.



*Figure 29. Wood frame uncovered next to wall, highlighted area shows wood frame with poured concrete filling the space between the wall and the frame.*



*Figure 30. Headrace area before excavation, highlighted area shows tree root that has disturbed the area.*

Trench01A before excavation clearly contained what had been the headrace of the mill, which was given the designation of PMF03. The area was obviously infiltrated by running water and was severely disturbed even during the operational period of the mill. Debris had gathered at the corner of the headrace and in the headrace, a large amount of soil had been deposited. A cypress knee protruded between the wall and the sides of the headrace causing it to shift from its original placement (Figure 30). Most of the excavation took place in the limits of the headrace itself and because the unit was of variable depths before excavation, removal of any material in the northern section of the unit was unnecessary and not completed. Further excavation of the very fragile headrace components also led to the decision to not remove any more material than necessary.

While excavating trench01A two types of concrete-like material were recovered through the screening process and hand collection. Differences in the concrete type was visible even in

the field and lab cleaning and analysis revealed even more differences. Table 5 shows the two types of concrete recovered from the unit by weight and quantity. The smaller pieces of concrete that were collected during excavation were variable in size and shape, they contained similar small white stone aggregate observed in the poured concrete found in PMF04 (figure 31). The material hand collected from PMF03 was collected with the intention of determining the source of the concrete used during construction. PMF03.1 (Figure 32) has a small piece of metal embedded in it holding the two sections together. This was not the only piece with observed metal embedded in the material, though there did not seem to be a pattern to the metal, such as the patterns seen in metal screen reinforcement lath or rebar. Other pieces also contained metal, though the metal was not embedded within the fragments as in PMF03.1. Some of the smaller pieces collected that are lacking clear aggregate have linear indentations created from being poured into a frame (Figure 33). The headrace itself consisted of a mortar type material without any large aggregate pieces; all of the collected sections were flat and broad.

*Table 5. Type of concrete recovered, counted and weighed in the lab.*

<b>Construction Material</b>	<b>Trench01</b>	<b>Trench02</b>	<b>Total</b>	<b>Weight</b>
White Aggregate Visible	21	0	21	2749 g
No Aggregate	0	2	2	392 g
Green Paint	0	3	3	763 g
Metal	7	0	7	2740 g



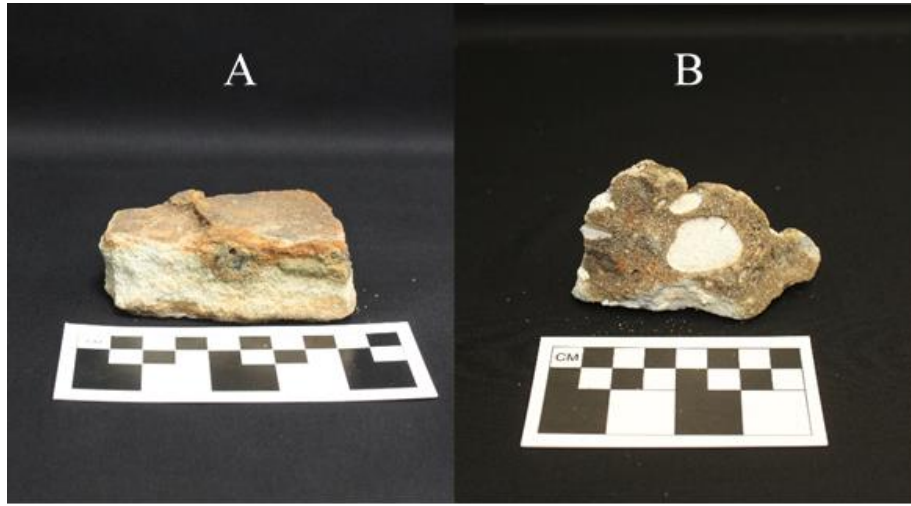

Figure 31. Two samples of concrete recovered from trench01A. Artifact A, shows a solid material with no larger aggregate pieces. Artifact B, shows concrete with large pieces of white stone aggregate visible.



Figure 32. PMFea03.1, Piece of hand collected headrace, material is broad and flat without any large aggregate pieces. Arrow points to metal inside of material.

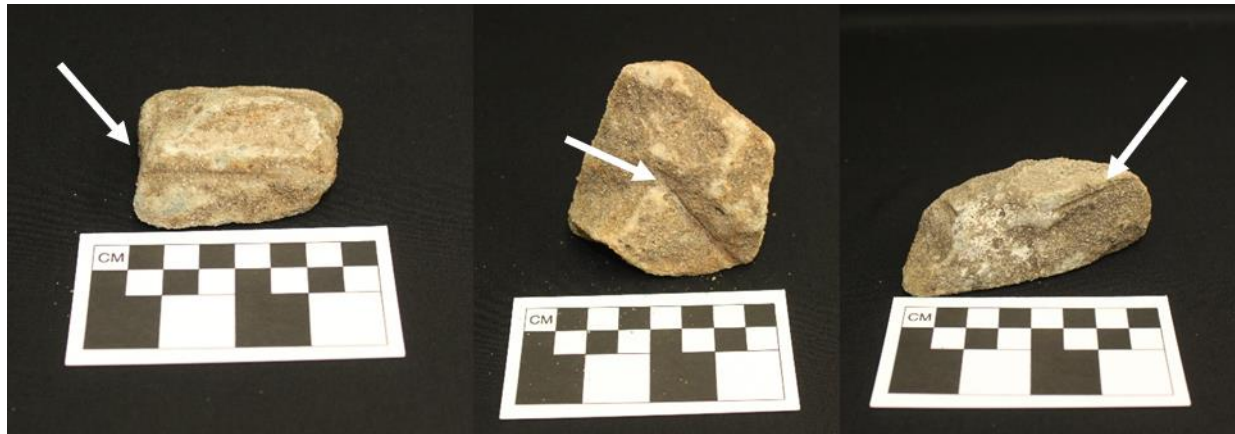

Figure 33. Small pieces of concrete with visible mold markings.



Figure 34. Headrace fully excavated. Photo shows depth of south side of headrace in relation to the original soil level.

As the headrace was excavated, it was revealed that the headrace sloped up towards the mill (Figure 34) and was made of a similar material throughout. Due to water intrusion within the area, a modern glass bottle along with a wood plank had been deposited inside the headrace and were found at the bottom of the unit. This made the use of stratigraphy to determine context and age virtually impossible. Where the headrace met the PMF07, it could be observed that the two pieces were not one unit, but rather constructed separately. Supporting structures, which was material that is visually different than that of the headrace, had been emplaced to stabilize the walls of the headrace (Figure 35).

Trench01 revealed much about the construction of the mill, and how the water may have caused the destruction of the original material. PMF07, which would have taken the brunt of the force of the water, has been reconstructed by later caretakers of the mill. The change in construction material that was observed while excavating trench01B and trench01A proves, at

the very least, that the builders had to adjust their techniques at some point during the life of the mill. The need to put in place a reinforcement structure against the north wall of the headrace also demonstrates later modifications. These additions and adjustments in construction make the analysis process more challenging, due to the variable age differences of the material used.



*Figure 35. Headrace at opening to sluice. A, shows the area where the headrace and wall would have touched but not connected structurally. B, shows the support structure put in place to the north of the headrace.*

## Trench02

While trench01 was excavated with the specific intention of excavating the headrace and revealing the extent of the masonry units that are visible above ground, trench02 was excavated with a concentration on a rectangular concrete feature. This feature is located parallel to the sluice and is directly underneath the remaining axle (Figure 36). Observations in the field led me to believe that it may have contained pieces of the gear mechanism that was once turned by the

water wheel. Again, the trench was split into units, this time two: trench02A and trench02B. Trench02A was specifically within the bounds of the visible barriers of the box and trench02B was set up as a 50cm x 1m unit directly to the northeast of the box (Figure 37). Both units were excavated by level using an arbitrary level of 10cm. Trench02A was shifted to natural levels after a soil change was detected 5cm down.



*Figure 36. Gear box before excavation.*

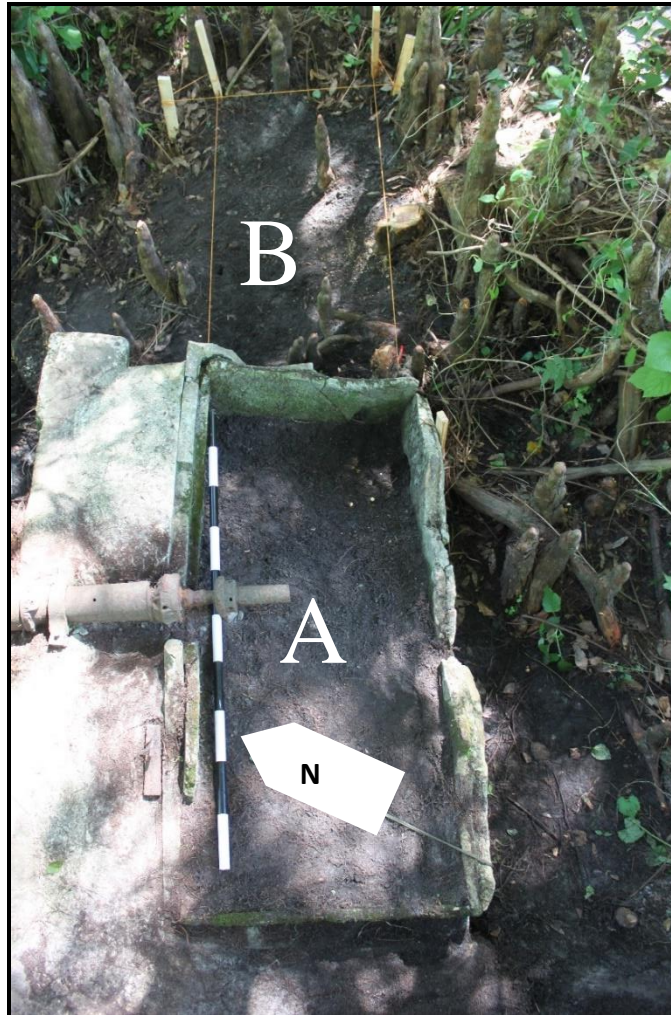

*Figure 37. Trench02 and sections A and B labeled.*

Level one of trench02A contained several relevant artifacts related to the portion of the axle that was protruding over the unit. Two pieces of metal had been documented before excavations began, one laying to the west of the axle and one directly underneath the axle. The correlation of these to the axle would not be clear until the other pieces were excavated. As level one was excavated two more metal artifacts were recovered and pedestaled to preserve the context (Figure 37). Along with the metal, several pieces of plaster-like material were recovered and as well as several pieces of concrete with green paint that was revealed after

cleaning in the lab (Figure 38). Though the concrete recovered was not of the same make up as that found in trench01 it was recovered and bagged for lab analysis. Once the metal artifacts were collected and bagged, it became clear that they had once been attached to the part of the axle that protruded over trench02A. The protruding axle became PMFea01 and when the metal pieces are held up to the axle they make up what would have been the points of attachment for a gear that would have been turned by the waterwheel (Figure 39). The gear attachment spokes each had a bolt on one end and had obvious break marks on the other end, of the six spots for spokes on the axle only four were recovered, the fifth remaining one is still attached and was only visible after the excavation of level one.



Figure 38. Metal fragments from gear attachments in situ and drawing of gear attachment as it may have looked when used on a similar style mill and wheel set up (Reynolds 1983:289).



*Figure 39. Pieces of gear attachment being held up to axle for context of possible attachment points.*

In level two of trench02A other pieces of the gear were recovered through screening. Four metal screws were found in the screen (Figure 40) and are heavily rusted: identification as screws were only made in the lab after cleaning. Two more pieces of concrete with green paint chips were recovered, and again the green paint was only visible after cleaning in the lab (Figure 41). The most intriguing find of level two consisted of eight pieces of plaster with metal lath attached, these appear to be modern and have what may be tar paper attached to one side (Figure 42). Metal lath was invented in 1797 but only came into use in the United States towards the end of the nineteenth century. By 1930, another type of lath known as rock lath was used exclusively

in residential plastering to secure plaster to flat surface; before metal lath was used, wood slats were employed for the same purpose. This makes dating the lath recovered at the mill site relatively easy (MacDonald 1984:4). The metal lath and plaster that was found in the gear box indicate late-nineteenth to 1930's construction and use of the mill. Level two also revealed small flat metal pieces that may have been part of a gear or paneling. The pieces were variable in width and size though none were over 3 cm. Level two ended when we excavated to the floor of the gear box.

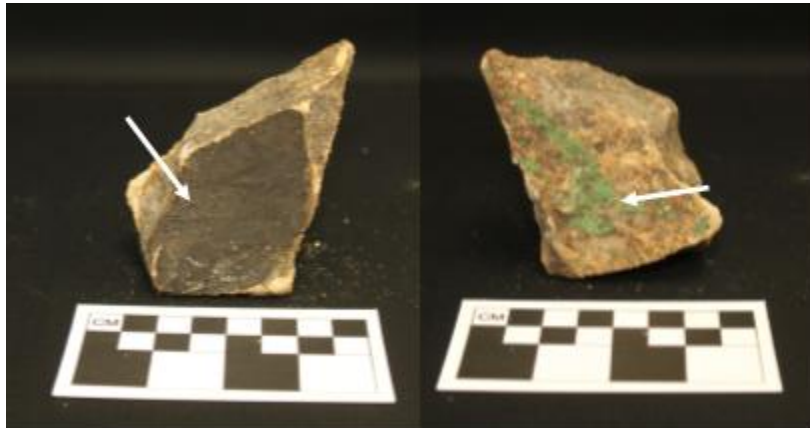

*Figure 40. Screw recovered while excavating trench02A (gear box).*



*Figure 41. Example of plaster and lath material recovered in trench02A.*





*Figure 42. Concrete with tar paper and green paint on opposite sides.*

The floor of the gear box was well preserved, easily cleaned for photographing, and was designated PMFea02. The floor was left intact, not collected, and covered after excavation for preservation. The floor appeared to be made out of the same concrete material as the wall of the box and had residual black material in some sections, possibly tar or grease. Two wood planks ran parallel to each other horizontally through the box, they were embedded into the concrete which appear to have been poured around the wood (Figure 43). Nail holes were visible though no nails were observed or recovered. Each plank was 10 cm wide and the space between them was 12- 15 cm, whereas the space between the wood planks and the wall was only 5 cm on either side. The north plank led to a hole in the wall of the box that seemed intentional and may have served as a drain for cleaning or water intrusion within the box (Figure 44). It was possible to determine the width of the gear, based on the width of the box and the placement of the wood planks, this is described further in Chapter 6.



Figure 43. Floor of gear box. Wood inserts are visible and run parallel to each other. One wood plank seems to line up with a drain hole in the east wall of the box. Reason for wood panels is unknown though given the alignment with the gear attachment arms it may have been related to the gear placement.



Figure 44. Drain hole in the eastern wall of the gear box.

## Shovel Tests

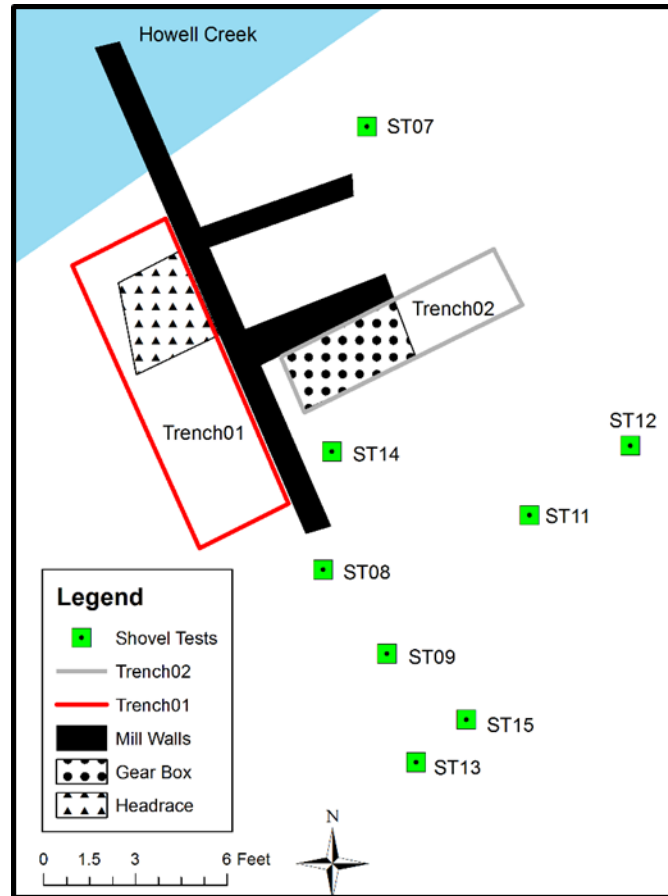

Figure 45. All units that were excavated and all shovel tests that were completed.

Eight shovel tests were completed (Figure 45), seven to the south of the mill where the mill housing would have been constructed and one to the north. It was the intention of these shovel tests to find any evidence of the mill housing and determine, if possible, its extent. Shovel tests 08, 09, 10, 13, and 15 were placed to the south of the dam wall in the hopes of finding the extent of that wall and any connection it may have had to the mill house. Shovel tests 11 and 12 were placed directly south of the gear box uphill from the mill where modern fill may have covered any remains of the building. Shovel Test 13 and 15 were placed to the southwest of ST 8 and 9 in an attempt to find the extent of the wall, small metal fragments were recovered

(Figure 46). Shovel test 14 was placed where a wood plank appeared to be sticking up out of the ground to find its extent and proper size. Shovel test 07 was placed where a flat piece of metal was found sticking out of the ground again to reveal the artifact and determine its extent. Shovel test 12 was sterile, as was shovel test 07, except a modern metal panel uncovered that did not appear to be associated with the mill. In shovel test 08, a small metal hinge was recovered in the screen though heavy oxidation makes diagnostics difficult.



*Figure 46. Metal found in shovel test 13.*

Shovel tests 08 and 09 eventually became one unit when a large field of concrete debris was revealed (Figure 47). The debris appeared to have the same characteristics of the smaller pieces collected during the excavation of trench01. They were all made of concrete with the same small white stone aggregate and had linear textures from what may have been a mold (Figure 48). No modern concrete masonry units, datable to the twentieth century, were recovered from the southern debris field. The concrete debris continue into the hill towards the south away from the mill; two further shovel tests were dug in order to find the extent of the debris. In the subsequent shovel tests, 15 and 13, no further debris was found though two small

pieces of metal were recovered in the screen (see also Figure 46). Due to heavy oxidization, their use or exact shape is not determinable. The soil in and around the debris field was very similar to the loamy soil that was predominant around the headrace, but under the debris it turned to a very sandy white. See appendix C for a profile of one of the negative shovel tests.



Figure 47. Planview of south debris field, ST08 and ST09 revealed the extent of this area.



Figure 48. Wall Debris showing white stone aggregate and mold markings.

Shovel test 14 was placed where a wooden board had begun to emerge from the ground. A nail could be observed sticking out from the end of the wood and was collected in the hopes it could be used for diagnostic purposes. The board was found to be 14 cm x 14 cm, almost a perfectly square beam, the true length of the beam is unknown due to time constraints and the depth at which it went into the hill to the south of the mill. The end of the board was excavated and had been cut at an angle, indicating it may have been a roof beam. A nail was recovered from the end of the wooden beam and though highly degraded appeared to have a twist to the body of the nail. It measured 16 cm in length and contained retained wood fragments around the head (Figure 49). It appears the nail is not a cut nail which would date to the mid-nineteenth century, and instead appears to be a machine-made nail made of steel or some other metal other than iron. The lack of oxidation lends to the nail being more modern or made of a metal that withstands rust more readily. There were no observable milling marks on the wood though its condition and the wet conditions of the area may have influenced wear on the board (Figure 50).



*Figure 49. Board found in shovel test 14.*



*Figure 50. Nail recovered from top of wood beam found in a shovel test. The nail has a twist in the body that is visible is most likely a modern nail.*

In chapter 6, results of the measurements taken in the field will be further discussed as well as a comprehensive look at the concrete that was recovered during the excavations. In that chapter, I will also attempt to connect the differences in material to both the original foundation of the mill and determine for how long the mill may have been in use. The measurements of the mill will be used to approximate the power output of the mill and what type of production that power could have sustained.

## CHAPTER SIX: DISCUSSION/CONCLUSION

There remains a great deal unknown since testing was unable to be performed on a majority of the artifacts recovered. However, I can still extrapolate a significant amount of information from the physical data and context of each artifact recovered. The largest data set is a detailed set of measurements of the existing mill structure, which can be used to approximate the original size of and potential power generated by the wheel. This chapter will outline information gathered from measurements at the mill and the construction material that was found beneath the modern masonry units that are visible and their potential origins are discussed as well.

### Discussion

The visible structure of the mill is of vital importance for understanding the mill itself and how it would have performed. Along with the information collected from the artifacts recovered during the excavations around the mill, data about the mill structure was collected through both the measuring of the physical structure itself, and through the collection of GIS data points. The intention of the excavations and the collection of the existing structure's data as described in the previous chapter was to determine the capabilities and physical form of the mill: construction methods and material used by the millwright, the size of wheel it could have supported, how much water volume it had been designed to handle, and how much power the wheel and water supply could have produced.

### Design of the Mill

The examination of the construction of the mill does not focus on the material; that will come in a later section. Instead, here I use the measurements and observations taken during the



field work to recreate how the mill would have operated. I also attempt to determine what design decisions Partin would have been made based on the information available to him and the available resources of the area. The type of wheel used, size of the wheel, volume of water that the mill could have handled, and the potential power the mill could have produced are all calculated.

### Type of Wheel

As discussed in Chapter 2, there are three predominant types of watermill wheels: undershot, overshot, and breastshot. These are often easily identifiable by the location of the headrace in relation to the wheel placement. Overshot and breast shot wheels have a headrace located above the wheel or even with the wheel's axle, respectively. Undershot wheels have a headrace that is even with the bottom of the wheel and directs the water under the wheel.

Howell creek does not produce a large volume of head and even with a dam the creek would not have supported a large mill. The axle rests on top of the sluice walls with the opening from the headrace resting on the ground level with the sluice floor (Figure 51). Further evidence can be found in the shape and size of the headrace, which Pallett (1866:229) says should be more of a square shape which would feed into a narrow sluice with a narrow wheel. The dimensions of the headrace and sluice of the Partin mill certainly fit within this description (figures 52 and 53). This visible evidence and Hunter's (1979:65) argument that undershot wheels were ideal for minimal water fall with a steady stream of water further solidify the argument that the Partin mill was an undershot wheel. Based on the Partin mill's headrace being located on the ground and significantly lower than the remaining axle, as can be seen in Figure 51, a low flow creek, and the size and construction of the headrace, the wheel would be classified as an undershot wheel.

Due to an undershot waterwheel's ability to function at low rates of flow, it would seem logical that Partin would have chosen that type of construction given the lower flow nature of Howell Creek.



*Figure 51. Headrace shown on the right connects to the sluice below the center of the wheel or in this case the observable axle.*

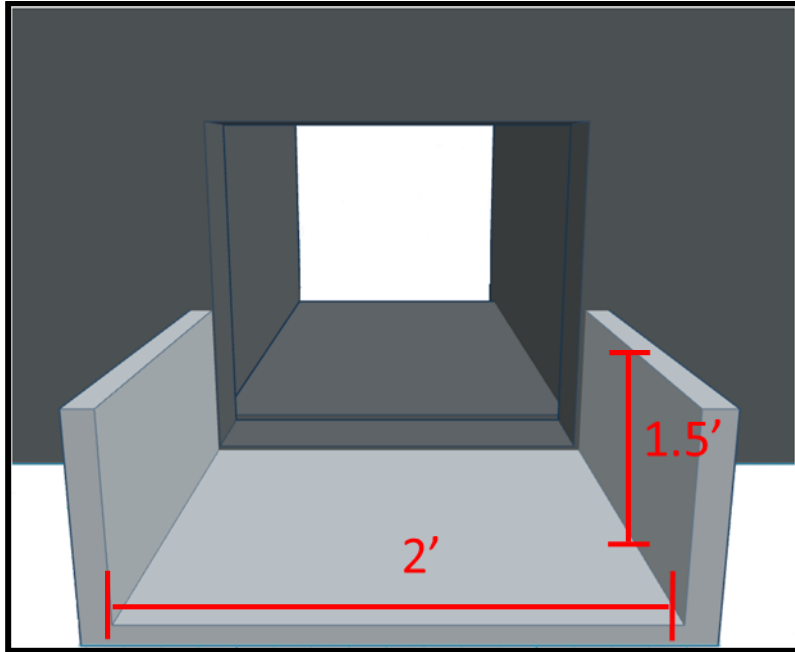

Figure 52. Rendering of headrace with dimensions, reconstruction by author.

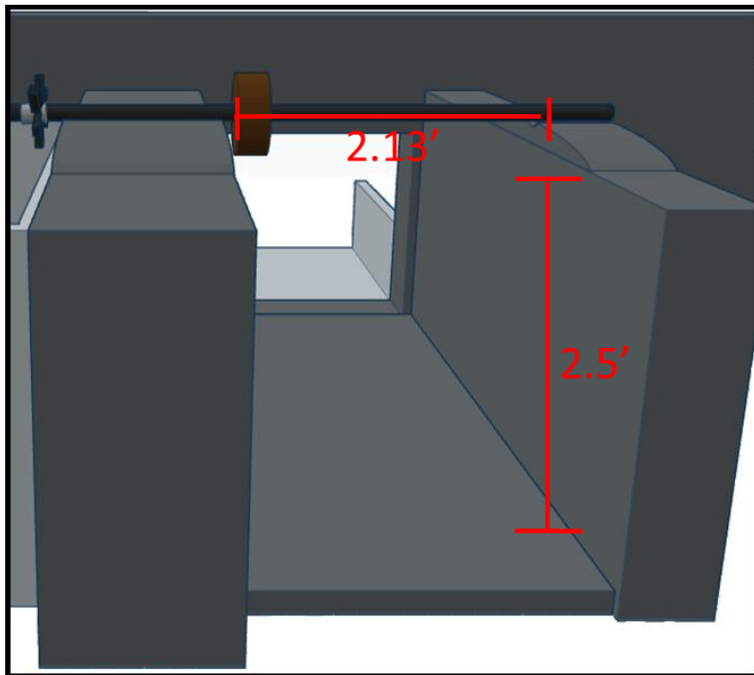

Figure 53. Rendering of sluice and axle with dimensions, reconstruction by author.

### Size of the Wheel

Though the wheel is gone, its approximate size can be determined within a range of minimum possible size and maximum possible size. The circumference of the wheel would be the first and most useful piece of information that can be determined from simple measurements of a possible radius dimension. The exact radius is unknown but a probable range was determined based on marks on the sluice walls. The maximum range consists of the distance from the floor of the sluice up to the center bar of the axle (24.5") (Figure 54). The middle of the headrace opening up to the center bar of the axle is the minimum radius (15"). The radius range is thus between 15 inches and 24.5 inches. Using the circumference formula of 3.14 for  $\pi$  and the two numbers for the radius a circumference can be determined.

$$C = 2\pi r$$

The possible range of the mill wheel circumference would thus be between 94 in. - 153 in.



*Figure 54. Maximum range of wheel radius.*

The range of possible sizes of the gear was determined using the same method. A minimum of 4.5 inches was determined using the spokes that protruded from the shaft and a

maximum of 9.65 inches from a measurement from the shaft to the floor of the box. The gear had a possible range of circumference 28.25 inches and 60.54 inches.

### Volume of Water Available

The volume of the water that would have flowed through the sluice thereby turning the wheel would determine the possible power output of the mill. While the wheel turned, the attached gear would have turned the apparatus the mill was built to power. To determine the amount of volume the mill was designed to handle, measurements of the headrace and sluice were taken (Figure 55). The formula for the volume of a rectangular prism was used and two ranges of measurements were obtained. Again, a probable minimum and maximum were determined; the maximum being the entire size of the headrace opening and the minimum reducing the size to half of the headrace opening vertically. The length of the sluice itself was used for length measurement. This is assuming that the mill would not have been able to run at a usable capacity or efficiency with the water lower than the half way mark on the headrace opening.

$$V = \ell w h$$

Given those assumptions, the possible range of volume is 3.89 ft<sup>3</sup> and 7.77 ft<sup>3</sup>.

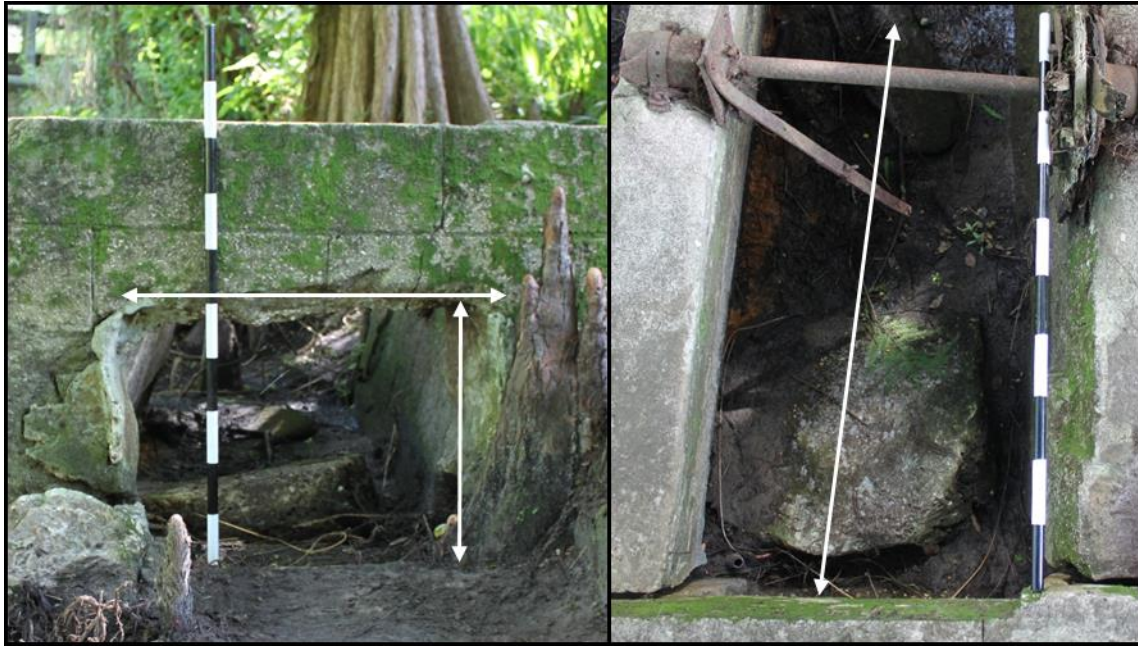

*Figure 55. Areas measured to figure out volume for mill.*

### Power Output

The power can be determined from using the information derived from the above formulas and hydrology data retrieved from historic water monitoring stations along Howell Creek. In order to determine the kilowatts generated by the wheel, the known velocity, or speed, and volume of water in the creek is used to determine the head measurement of the water flow. The head, defined as how far the water falls, and the velocity were then used to determine the potential power of the wheel.

According to both a modern and historic millwright's instruction guide on building undershot wheels, knowing the head is essential to determining the appropriate size wheel needed to achieve maximum efficiency (Behrens 1992; Pallett 1866:228). The head measurement of the creek was determined based on the hydrology data pulled from the water monitoring stations located along the creek. In chapter 2, the volume of the creek between 1972

and 2016 was determined to have an average of 128.5 cubic feet per second (CFS), with a low of 6 CFS and high of 444 CFS. For the purposes of this work, I will focus on the low range. The head of a creek or river is how far the water falls, either from the top of a dam to the bottom or how long it takes the water to travel between predetermined two points (Leffel 1881:153). For this work since the height of the dam is unknown, if there was one at all, the known historic velocity of the creek will be used. I evaluated the head of Howell Creek using the following formula, with  $v$  being the velocity of the creek at its lowest velocity and  $G$  being gravitational constant of 32.2 (Behrens 1992).

$$\frac{v^2}{2G}$$

The head or descent of Howell Creek was determined to be .559 feet, having used the average velocity or  $v = 128.5$  CFS the head would have been 256 feet.

Another way to determine the head, and maybe more accurately, would be to find historical range of wheel diameter based on available head and work backwards using the estimated diameter. The optimal diameter of the wheel for an undershot is 3 to 6 times the known head (Behrens 1992); this is essential since the undershot wheel relies heavily on the moving water and hardly at all on gravity (Pallett 1866: 229). Given the head of .559 feet and following the above formula a range of efficient wheel size can be determined. For the formula  $h$  is head.

$$h * 3(\text{low range of head}) = \text{diameter in feet}$$

$$h * 6(\text{high range of head}) = \text{diameter in feet}$$

The range of possible diameters that would have been efficient given the minimum head known for Howell creek would be 20 inches for the minimum and 40.25 inches for the maximum.

Given that the measured diameter range taken from the existing mill was between 31.25 inches and 51 inches, it can be presumed that the mill would most likely have been built to most efficiently handle a head of no more than a foot and no less than 5 inches. It is evident based on the appearance of the creek today that the water levels have changed drastically, either through modern construction or natural deviations in the creek bed.

Based on the preceding information, I was able to determine the approximate kilowatts the mill produced. The width of the wheel is the essential last piece to this formula; the remaining axle at the mill site has some remaining pieces of the wheel where it was attached and shows the wheel to have been no wider than 20.75 inches. The design flow ( $df$ ) is determined by using the width of the wheel ( $w$ ) of 1.75 foot, head ( $h$ ) of 1 foot, and lowest recorded velocity of Howell Creek ( $v$ ) of 6 CFS.

$$w \cdot h \cdot v = df$$

The design flow for the Partin mill, which is 10.5 cubic feet per second, is then used to figure out the kilowatts generated. The constant of 11.8 is used as a constant for the kilowatt formula.

$$\frac{df \cdot h}{11.8}$$

The idealized mill design of this wheel, without accounting for loss and utilizing minimum recorded historic flow data, would generate 5.34 kilowatts or 5340 watts, or 7hp, which could potentially turn a millstone four feet in diameter and produce 300 to 500 pounds of grist a day.



## Construction Material

The construction material recovered at the site was collected in the hopes that it would help date the site and determine the construction methods that Partin would have used in the construction of the mill. Concrete appeared to be the main type of material used and due to its long history of use it has been difficult without other forms of analysis to determine its exact age or make up.

### Concrete

The visible mill structure has what are considered modern concrete masonry units that were not widely used until the early twentieth century, long after the historical record shows the Partin mill being constructed. Modern concrete also known as Portland cement was developed and began being used in construction as early as 1824 (Potter 1877:24), but the use of Portland cement being made into hollow concrete masonry units (CMU) only became possible in 1866 when techniques improved to make the blocks easier to handle (Drysdale et al. 1994:5). This would lead to the argument that the visible blocks that are a part of PMF07, are not part of the original mill structure, given that the historical record has the mill being built in 1866.

The other type of concrete that was present after excavations, mostly found in ST 10, is more similar to hydraulic cement. Hydraulic cement, much like CMU's, is poured into molds and laid out much like brick would be (Potter 1877:24), they are also characterized as having visible aggregate such as natural stones (Mack and Speweik 1998:6). Hydraulic cement when first used was particularly useful in wet environments due to its hardness when inundated with water. Portland cement tends to have a very uniform look and feel whereas other types of cement tend to be less uniform and vary in textures.

It can be presumed that the current structure is a more modern construction of the mill either in an effort to repair the structure for continued use or to preserve the structure. The material underneath the masonry units is different in makeup and structure, leading me to believe that some of the original construction has survived. The pieces that were recovered during excavations were bagged and taken to the lab for analysis. They revealed some interesting qualities once cleaned. It is impossible to determine the exact elemental makeup of the pieces without analyzation through techniques such as pXRF or petrographic analysis. By referencing the history of concrete in America, and determining if Partin would have had access to the material needed to make concrete, can lead us to a hypothesis that the remaining concrete is original. Both debris fields, the one in the creek and the one excavated in ST9 and 10 reveal how much concrete may have been used.

### Bricks

In the creek debris field, several bricks were found and several of those had makers' marks. Makers' marks are nearly a time stamp of when the brick was manufactured, giving me a definitive oldest possible age of the mill. The particular bricks and marks that were found are known as fire bricks most often used in fireplaces because of their size and heat resistance. Though these bricks did not show signs of fire exposure, they could very well have been a part of a fireplace for the mill. Two with significant markings were collected and the others were left in situ and counted. In total, there were 62 bricks or pieces of brick.

The two that were collected were measured and weighed in the lab and the markings recorded. Brick01 weighed 2906 g and measured 22.68 cm x 11.3cm x 6.4 cm. The mark on it, Stevens Kaofrax (Figure 56), can be traced back to the Stevens Brothers Company from Macon,

Georgia. Stevens produced brick and erected mills until 1854, when he entered the brick making business (The Southern Historical Association [SHA] 1895:274). Kaofrax is a combination of the type of clay used in making the brick and the method of making it. It is quite possible that these bricks had been used before and were being reused in the construction of the mill. Though they do prove that the mill cannot be older than 1850, they cannot with certainty prove that the mill was built in 1866 as the historic record shows since the brick manufacturer produced similar bricks until the early 1900's.



Figure 56. Brick recovered from creek with Makers mark on it. Stevens Kaofrax was traced to Middle Georgia.

### Conclusion

Throughout this thesis, I used spatial analysis and field excavation methods to archaeologically answer questions about Hugh Partin and a mill he built in Central Florida. Connecting the information recovered through excavations to *chaîne opératoire* and Marxist ideas of production and political relationships I have come to understand how he designed the

mill, what construction methods he used to construct that mill, and how he used that mill to gain not only power for himself and his posterity but also for the larger community he served. In order to bring this mill and its history back into focus and properly document it, I directed the focus of this research on the remaining mill foundation and the construction techniques used by Hugh Partin to build the mill.

The location of the mill was found through the GIS predictive model and a subsequent survey of the area. A combination of property ownership records and hydrology data of the area were used to determine the probable areas that could have supported a mill and their overlap with lands owned by Partin, Mizell, or Holden. The mill was found less than one half mile from the family burial plot along Howell creek, a creek that runs north to the St. Johns, the very river that Partin traveled south on with his family. Howell Creek, where the remains of the mill stand today, is a clear flowing creek that runs past the land that held the Partin settlement. Though this model was successful in finding the Partin mill, the true success of this model will be indicated by uncovering other forgotten mills through its reproduction.

Excavations of the mill revealed much about the mill and its construction, though not all questions have been answered. The visible features are made of modern concrete masonry units, the exact kind you might find in a modern home. In the creek, the debris of this modern material is mixed among bricks that can be dated to the 1850's and modern refuse such as soda bottles. From the outset, it seemed almost impossible to date the material or determine the original structure. As excavations progressed, a different type of concrete material was revealed: concrete more consistent with late 1800's technology. It is very probable that Partin would have had access to and knowledge of concrete technology, this also points to later use of the mill

possibly well into the twentieth century. The remaining question is: would he have used this technology for his mill? If the secondary excavated concrete material is original to the mill, it represents a great deal of how Partin was using new technology in a frontier environment to increase his power and position in the community. It is also a statement of how he brought knowledge with him and then used it in this new environment. Little was found in the way of personal material remains or definitive answers on construction methods. This may be due to natural and human disturbances in the area and an obvious effort to preserve the mill foundation; the Partins and their technologies most certainly left a mark on the landscape. The lack of remains could indicate later occupations, this theory is bolstered by the more modern fixtures of the existing mill. It is also possible that the current location is not the original and instead a later mill was constructed by other occupants. It is unlikely that the mill would have been fixed or repaired in order to simply preserve so this could indicate prolonged use of the area and the technology.

The Partin mill was a small watermill built in Central Florida in 1866, merely a year after the end of the Civil War. Until recently, only the descendants of the millwright himself expressed much interest in Hugh G. Partin's story and industry. A few newspaper articles and a line or two in local history books were all that existed to prove that a mill had once been the focus of an entire family and the subsequent legacy they would build for themselves in the Orlando and greater Central Florida community. Partin, the patriarch of his family, became a county commissioner; one of his grandsons was a wealthy cattle baron who was partly responsible for the booming cattle industry of Central Florida; his third son was the county tax assessor (Heatherington 1980:33); and schools in Seminole and Osceola counties bear the Partin

name to this day (Robison 2002). The probable area of the settlement has been paved over and swallowed up by suburbia, except for the family cemetery. The mill foundation itself spends a majority of the year covered by vegetation, invisible to the cars passing less than 50 feet away. A piece of forgotten local history has gone unrecorded.

What can be determined from the minimal historical records is that Hugh Partin walked from southeast Georgia to Florida in 1847, looking for a new place to raise his family. As this was before the Civil War, economic necessity due to hardship within the settled South or merely the opportunity to start a new legacy for his family may have driven his migration to new lands. He found a suitable place in the frontier of Central Florida and brought his family to join him. Partin was already an established millwright in Georgia; he carried that trade and knowledge with him to Florida. The family began the trip in 1858, stopping in several other regions of Florida and Georgia along the journey. A long eight years later, the Partin family finally reached the Orlando area in 1866. Partin then began the process of using his knowledge of mills to become employed to build a mill that would not only serve the community but establish a place for himself and his family in the community. A settlement was established and the Partins built a frame house, planted oranges, established a school, and started a family burial plot. Their settlement would soon reach 160 acres, giving Partin a place in the political landscape of Orlando and Orange County. There is no map showing the Partin home or mill location, no written records of building of the mill, and no account of how he would have constructed it.

As can be seen by this example, watermills large and small played such a significant role in the growing industry of our country that they have continued to hold our fascination well over a hundred years after the technology was rendered obsolete. The millwrights that built and ran

the mills were often held in high regard within the community; the mill houses themselves became community centers where people could gather. Often, mill ponds doubled as swimming holes and picnics were organized around running the mill (Georgia Department of Transportation [GDOT], Report on Ben Hill Mill 2015). Mills dotted the landscape: from the industrial textile mills to the community grist mills in both the North and South. Community mills seem to have become so prevalent that they often went overlooked on maps of many cities and towns. The location of smaller mills especially can only rarely be found on surveyor maps; often the only indicator that a mill once stood along a creek or river is a road with the name “mill” leading to it.

Research possibilities on the Partin mill are nowhere near exhausted, and additional research will only help further the knowledge and understanding of the Partin mill and its unique role in Central Florida’s history. The secondary concrete collected will need to be analyzed to determine its material composition. If the collected samples differ from materials found in Portland cement that would imply that Partin had knowledge of how to make concrete out of available materials. Further excavations to the south of the mill, further up the creek bank, may potentially reveal further evidence of the mill house and other material remains that may point to what the mill would have been producing. No archaeological evidence presently exists to suggest what type of production the mill was used for, and this must be answered in order to completely understand the mill and Partin.



*Figure 73. 1940 Aerial photo of mill area and cemetery. Proposed settlement area is also highlighted.*

Though the settlement is most likely covered by a neighborhood, any remains being greatly disturbed by the construction of pools and roads, knowing the homestead's location would present a much clearer image to the landscape Partin created and lived in. A survey of the neighborhood was completed with the help of the head of the neighborhood newsletter, and of the people living in the neighborhood, only a few original owners remained. They had no recollection of buildings being torn down and had not found anything in their yards that may be connected to the original settlement. A few bricks were located though dating was not possible due to lack of markings and the one that had a mark was from the modern era. There are aerial



photos of the area from the 1940's and in them the cemetery and a house can be made out. Several other features are visible such roads or pathways to where the mill may have been. Property records indicate that the land had changed hands several times by the time this photo was taken (Figure 57) so proving that the visible house is that of Hugh Partin is somewhat difficult. But, it is a place to start. Even though there is much left to discover about Hugh Partin and his mill, this research will enable both the mill and family burial plot to be placed on the Florida Master Site File. The material collected will be cataloged and stored with the State of Florida's Historic Preservation Office in Tallahassee, Florida. Finally, this thesis will give the Partin family and their posterity a greater understanding of their ancestor and a place within the history of the building of Orlando and Central Florida.

**APPENDIX A:  
STATE OF FLORIDA PERMIT AND SJRWMD EXEMPTION**



FLORIDA DEPARTMENT OF STATE  
 Ken Detzner  
 Secretary of State  
 DIVISION OF HISTORICAL RESOURCES

**ARCHAEOLOGICAL RESEARCH PERMIT**

Permit No. 1617.001      Field Begin Date: 6/23/2016      Field End Date: 6/23/2017

**PERMITTEE/AUTHORIZED ENTITY:**      Report/Artifact Due Date: 6/23/2018  
 University of Central Florida Department of Anthropology      Project: Partin Watermill  
 c/o Sarah B. Barber  
 with Elizabeth Chance Campbell  
 200 St. Andrews Blvd #2210  
 Winter Park, Florida 32792

This permit is issued under the authority of Chapters 267.031 (1) and 267.12, Florida Statutes (F.S.) and Rule 1A-32, Florida Administrative Code (F.A.C.), and is administered by the Florida Bureau of Archaeological Research (BAR), Florida Division of Historical Resources (DHR).

ACTIVITY DESCRIPTION:

Shovel tests, trenches

LOCATION DESCRIPTION:

81°19'23.124"W, 28°37'56.271"N, Howell Creek, Seminole County  
 DEP, Sovereignty Submerged Lands

GENERAL CONDITIONS:

1. The Principal Investigator listed above or another qualified archaeologist designated by the applicant shall be responsible for all archaeological investigations, production of a final report, and be on site during all fieldwork.
2. A copy of this permit shall be provided to the land managing agency (when applicable) and field personnel shall carry a copy during fieldwork.
3. The permittee shall (initial each item as indicated):
  - a. prepare a final report that meets standards and guidelines required by Rule 1A-46, F.A.C., including the necessary Florida Master Site File forms; *ABB*
  - b. inform the BAR permit administrator that a report has been completed and submitted to the Division of Historical Resources; or submit a copy of the final report to the BAR permit administrator; *ABB*
  - c. provide proper curation and conservation of recovered artifacts and other recovered site materials until such time as those artifacts and other site materials are conveyed to the BAR for curation; *ABB*
  - d. convey all artifacts and related materials obtained from state-owned or controlled land to the

500 S. Bronough Street • Tallahassee, FL 32399-0250 • <http://www.flheritage.com>

Director's Office       Archaeological Research       Historic Preservation  
 (850) 245-6300 • FAX: 245-6436      (850) 245-6444 • FAX: 245-6452      (850) 245-6333 • FAX: 245-6437

- BAR permit administrator for permanent curation or processing for loan; ~~ABP~~
- e. convey copies of all notes, maps, photographs, videotapes, and other field records pertaining to research conducted under this permit to the BAR permit administrator following completion of the project ~~ABP~~;
  - f. and not remove from a stable environment artifacts and materials which the permit recipient is unable to properly curate and conserve before conveying to BAR. ~~ABP~~
4. The effective field investigation dates are subject to receipt of permission from the land management agency and, in some instances, State/Federal dredge-and-fill permitting programs. Those agencies may also require work performance conditions relevant to their natural resource management and permitting responsibilities. A representative of the land managing agency (if one exists) will need to sign this permit document prior to BAR executing this permit (see page 3).
  5. Unless approved in writing by BAR, no work beyond that described in the "ACTIVITY DESCRIPTION" and attached to your application shall be performed.
  6. This permit is valid for up to one year following the requested report due date. Requests for approval for amendments to fieldwork, fieldwork end date and report/artifact due date are required during this time. Such requests may be made and approved by phone, email, or in writing during this time and do not require amendments to this document.
  7. In any release of information, including public presentations, media contacts, and the final written report, there shall be acknowledgement that the portion of the project involving state-owned and controlled land was conducted under the terms of an archaeological research permit issued by the Florida Department of State, Division of Historical Resources, Bureau of Archaeological Research.
  8. If Unmarked Human Burials are discovered, permit recipient shall comply with the provisions of 872.05, F.S., and when appropriate, Rule 1A-44, F.A.C. Specifically, upon discovery of unmarked human remains, all activities that might further affect those remains shall be halted and the remains protected from further disturbance until an appropriate course of action has been determined by the local medical examiner or by the State Archaeologist, as appropriate.
  9. In issuing this permit, the State assumes no liability for the acts, omissions to act or negligence of the permittee, its agents, servants or employees; nor shall this permittee exclude liability for its own acts, omissions to act or negligence to the State.
  10. The permittee, unless the permittee is an agency of the State, agrees to assume all responsibility for, indemnify, defend and hold harmless the Division of Historical Resources from and against any and all claims, demands, or liabilities, or suits of any nature whatsoever arising out of, because of, or due to any act or occurrence of omission or commission arising out of the permittee's operations pursuant to this permit and shall investigate all claims at its own expense. In addition, the permittee hereby agrees to be responsible for any injury or property damage resulting from any activities conducted by the permittee.
  11. The parties hereto agree that the permittee, its officers, agents and employees, in performance of this permit, shall act in the capacity of an independent contractor and not as an officer, employee, or agent of the State.

The undersigned, as representative of the Permittee/Authorized Entity, understands and accepts the terms of this 1A-32 Archaeological Research Permit.

Sarah B Barber

Date: 7/1/16

Signature

The undersigned, as representative of the land managing agency for the managed area/state property described in the "LOCATION DESCRIPTION" section of this document, hereby permits the activity described above.

\_\_\_\_\_ N/A \_\_\_\_\_

Date: \_\_\_\_\_ N/A \_\_\_\_\_

Title: \_\_\_\_\_ N/A \_\_\_\_\_

**This permit will not become effective until it has been executed by the Chief of BAR. Before BAR can execute this permit, the Permittee must have a land management representative (if applicable) sign in the space provided above. Please send the signed permit to the Permit Administrator at the address above.**

**A copy of the executed permit will be sent to you prior to commencing fieldwork.**

Executed in Tallahassee, Florida

STATE OF FLORIDA  
DEPARTMENT OF STATE

Mary Glowacki, Ph.D.  
FOR Chief, Bureau of Archaeological Research

7/5/16  
Date of Issue

Enclosures:

- Rule 1A-46, F.A.C.
- BAR Collections and Curation Guidelines
- How to Package Documents, Florida Master Site File

Copies furnished to:

MG/ICB



# St. Johns River Water Management District

Ann B. Shortelle, Ph.D., Executive Director

601 South Lake Destiny Road, Suite 200 • Maitland, FL 32751 • (407) 659-4800  
On the Internet at [www.sjrwm.com](http://www.sjrwm.com).

June 07, 2016

Elizabeth G Chance Campbell  
UCF  
Apt 2210  
200 Saint Andrews Blvd  
Winter Park, FL 32792-4248

Re: Partin Watermill  
Permit Number: 146430-1  
**(Please reference the permit number on all correspondence.)**

Dear Ms. Campbell:

On June 6, 2016, the St. Johns River Water Management District received your application supporting information and determination fee requesting an exemption verification for the above referenced project. Based on our discussion and your submittal, the proposed project involves the excavation of archeological artifacts within surface waters and wetlands as defined in Section 62-340 Florida Administrative Code at the site of the historic Partin Watermill site on Howell Creek.

Pursuant to 373.406(6), Florida Statutes (F.S.), an Environmental Resource Permit is not required as the District has determined that the proposed excavation will have no significant impact to water resources.

Please be advised that this determination only applies to the District and does not relieve you from the permitting requirements of other agencies.

Thank you for your cooperation with the permitting and compliance process. If you have any questions, please contact William Carlie, Compliance Coordinator at (407) 659-4833 or by email at [wcarlie@sjrwm.com](mailto:wcarlie@sjrwm.com).

Sincerely,

David Dewey  
Regulatory Coordinator  
Division of Regulatory Services

CC: Bill Carlie

**GOVERNING BOARD**

John A. Miklos, CHAIRMAN  
ORLANDO

Fred N. Roberts Jr., VICE CHAIRMAN  
OCALA

Chuck Drake, SECRETARY  
ORLANDO

Carla Yetter, TREASURER  
FERNANDINA BEACH

Douglas C. Bourmique  
VERO BEACH

John P. Browning, Jr.  
EAST PALATKA

Douglas Burnett  
ST. AUGUSTINE

Maryam H. Ghyabi  
ORMOND BEACH

Ron Howse  
COGDA

**APPENDIX B:  
FIELD FORMS**

Shovel Test Form

Excavators: \_\_\_\_\_

Project: <u>Partin Watermill</u>	Unit: _____	Date: _____
Excavation Method: _____		
Dimensions: _____		
SW Corner Coord: _____ X   _____ Y		
Elevation: _____ Z		
Screened: Yes _____ No _____	Size: 5mm	Artifacts Found: Yes _____ No _____

Use the template below to record stratigraphy. Describe the depth of each stratum. Place notes about artifact finds: their type and FS.LOT #. Provide additional comments as necessary.

0 \*All measurements in centimeters.

Notes:

5		
10		
15		
20		
25		
30		
35		
40		
45		
50		
55		
60		
65		
70		
75		
80		
85		

Project: Partin Watermill

Unit: \_\_\_\_\_

Page \_\_\_\_\_ of \_\_\_\_\_



Shovel Test Form

Excavators: \_\_\_\_\_

90	
95	
100	

List of Artifacts: Total: \_\_\_\_\_ FS.LOT#'s: \_\_\_\_\_ to \_\_\_\_\_

FS.LOT	Depth	Description

Notes:

**Unit Excavation Form**

Excavators: \_\_\_\_\_

Project: _____	Partin Watermill	Unit: _____	Date: _____
Excavation Method: _____			
Dimensions: _____			
SW Corner Coord: _____		X	Y
		Elevation: _____	Z
Trench: Yes _____ No _____	Screened: Yes _____ No _____	Size: 5mm	

Dates: \_\_\_\_\_ to \_\_\_\_\_

Top Elevations:	NW _____	NE _____	SW _____	SE _____
Bottom Elevations:	NW _____	NE _____	SW _____	SE _____
Total:	NW _____	NE _____	SW _____	SE _____
Matrix Color:	_____			

Features: \_\_\_\_\_

**Planview Sketch**

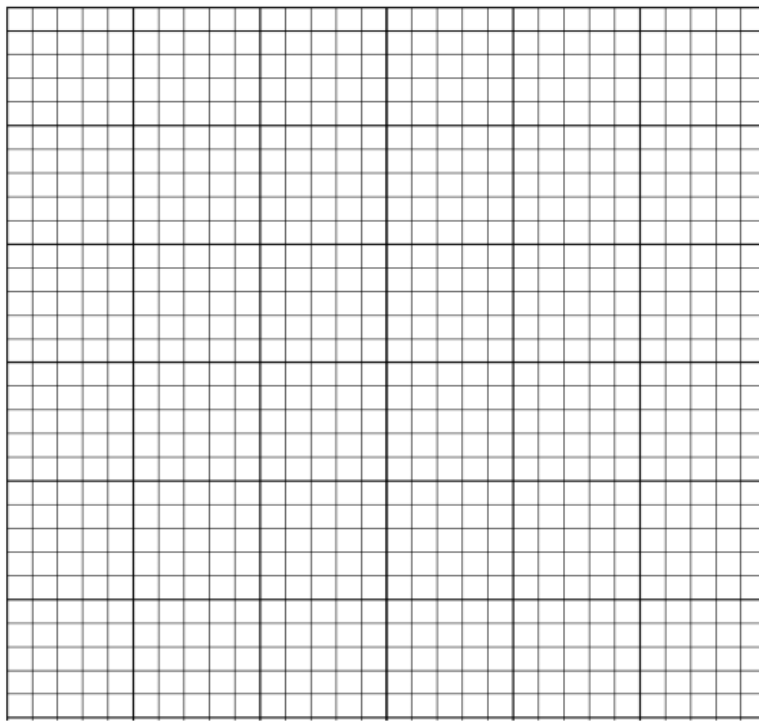

**Artifact Location**

Label:	Description:

Unit Excavation Form

Excavators: \_\_\_\_\_

Artifacts Discarded: \_\_\_\_\_

Photos: \_\_\_\_\_

Number	Description	Number	Description	Number	Description

List of Artifacts:

FS.LOT#	X	Y	Elevation	Level	Description

Field Notes:

Feature Form: Feature \_\_\_\_\_ FS.LOT# \_\_\_\_\_

Excavators: \_\_\_\_\_

Project: <u>Partin Watermill</u>	Unit: _____	Date: _____
Excavation Method: _____		
Description: _____		
Feature Coordinates: _____ X _____ Y		
Elevation: _____ Z		
Level: _____	Found in screen: Yes _____ No _____	Size: 5mm

Elevation Top: \_\_\_\_\_      Photos: 

Elevation Bottom: \_\_\_\_\_

Description:(munsell, texture, contents, disturbances, other)

Matrix: \_\_\_\_\_

Correlation with Stratigraphy: \_\_\_\_\_

Interpretation:

Project: Partin Watermill      Unit: \_\_\_\_\_      Page \_\_\_\_\_ of \_\_\_\_\_

**APPENDIX C:  
FIELD MAPS**

PI6 M  
Trench 04 Unit B/PMF 04 Profile

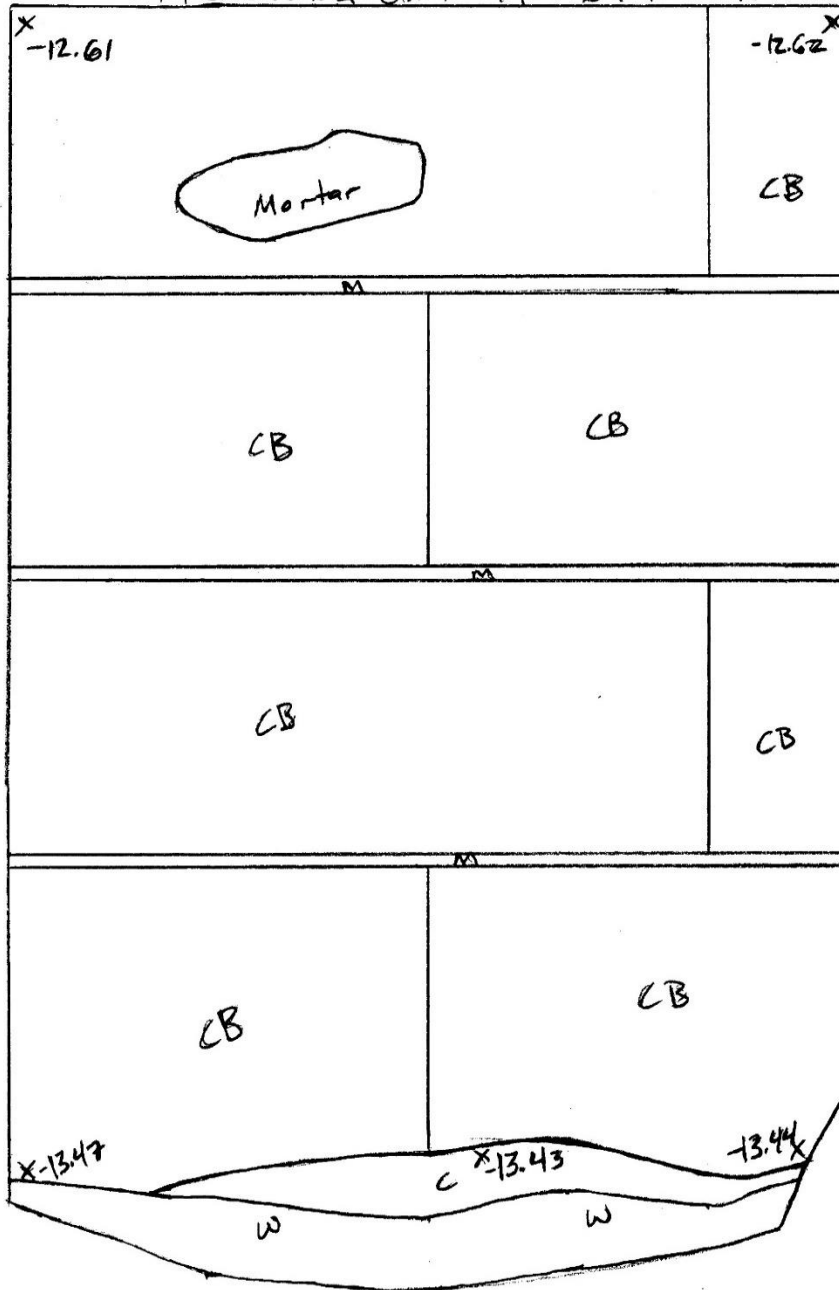

Coordinates  
468422.45x  
3167287.89y

Datum 07  
-12.72

CB - Concrete Block  
M - Mortar  
C - Concrete  
W - Wood

10cm



PIGM  
 Trench #1 Unit B/  
 AM F#4  
 Plan view  
 468422.63 x 3167287.43y

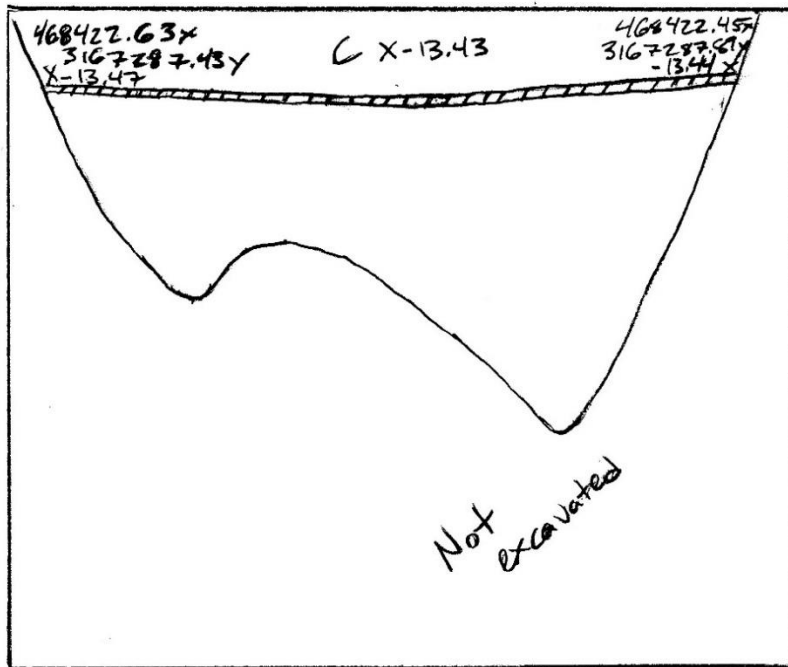

IIII - Wood  
 C - Concrete

10cm



Datum #7  
 -12.72

## LIST OF REFERENCES

- Adams, Sherman  
2007 Central Florida Genealogical Society. Online Quarterly, [http://cfigs.org/images/files/quarterly/bt200709\\_cfigs\\_quarterly\\_vol\\_39-3.pdf](http://cfigs.org/images/files/quarterly/bt200709_cfigs_quarterly_vol_39-3.pdf), Accessed April 2015.
- Bacon, Eve  
1975 *Orlando A Centennial History*. The Mickler House, Chuluota, Florida.
- Beatty, Bess  
1987 Lowells of the South: Northern Influences on the Nineteenth-Century North Carolina Textile Industry. *The Journal of Southern History* 53(1):37-62.
- Behrens, Rudy  
1992 Backwoods Home Magazine. Online article, <http://www.backwoodshome.com/design-calculations-for-no-head-low-head-waterwheels/>, Accessed July 2016.
- Bell, D.  
1998 The Social Relations of Property and Efficiency. In *Property in Economic Context*, edited by R.C. Hunt and A. Gilman, 29-45. University Press American, Lanham, Maryland.
- Blackman, William Freemont  
1927 *History of Orange County Florida*. The E.O. Painter Printing, DeLand, Florida.
- Cash, W.T.  
1938 *The Story of Florida*. The American Historical Society, New York.
- Cohn, Raymond  
1980 Local Manufacturing in the Antebellum South and Midwest. *The Business History review* 54(1):80-91.
- Cresswell, Robert  
1993 Of Mills and Waterwheels: The Hidden Parameters of Technological Choice. In *Technological Choices: Transformation in Material Cultures since the Neolithic*, edited by Pierre Lemonnier, 181-213. Routledge, London.
- Dobres, Marcia-Anne  
2000 *Technology and Social Agency*. Blackwell Publishers, Oxford.  
2010 Archaeologies of Technology. *Cambridge Journal of Economics* 34(1):103-114.
- Drysdale, Robert G., Ahmad A. Hamid, and Lawrie R. Baker



- 1994 *Masonry Structures: Behavior and Design*. Prentice-Hall, Englewood Cliffs, California.
- Earle, Timothy  
2000 Archaeology, Property, and Prehistory. *Annual Review of Anthropology* 29:39-60.
- Elliott, Rita  
2003 *Georgia's Inland Waters*. Southern Research Historic Preservation Consultants, Atlanta.
- Engineers Australia  
Australian Education Resources. Webpage,  
<http://www.forteachersforstudents.com.au/site/themed-curriculum/water-wheels/facts/>,  
accessed December 2016.
- Evans, Oliver  
1795 *The Young Mill-wright and Millers Guide*. Oliver Evans, Philadelphia.
- FGDL Metadata Explorer.  
GIS Database. Database, <http://www.fgdl.org/metadataexplorer/explorer.jsp>, Accessed  
2016.
- Florida State Parks  
O'Leno State Park Website, <https://www.floridastateparks.org/park-history/Oleno>,  
accessed July 25, 2016.
- Georgia Department of Transportation  
2015 *Ben Hill Report*. Bridge Expansion Survey. Submitted to GDOT, Report No.  
0011676
- Hasse, Larry  
1984 Watermills in the South: Rural Institutions Working against Modernization.  
*Agricultural History* 58(3):280-295.
- Hetherington, Alma  
1980 *The River of the Long Water*. Mickler House Publishers, Chuluota, Florida.
- Hunter, Louis C.  
1979 *A History of Industrial Power in the United States, 1780-1930*. University Press  
of Virginia, Charlottesville.
- Jones, William  
1981 A British Period Water Sawmill: Flagler County. *El Escribano Magazine* 84-105.

- Kendrick, Baynard  
1976 *Orlando a Century Plus*. Sentinel Star Company, Orlando.
- Laland, Patricia  
2001 The Legacy of Water Mills. *Early American Life* 32(1):38-44.
- Leffel, James  
1881 *Leffel's Construction of Mill Dams and Bookwalter's Millwright and Mechanic*. James Leffel & Co, Springfield.
- MacDonald, Marylee  
1984 Repairing Historic Flat Plaster-Walls and Ceilings. *Preservation Briefs, U.S. Department of the Interior* 1-14.
- MacDowell, Claire Leavitt  
1950 *A Chronological History of Winter Park, Florida*. Orange Press, Orlando.
- Mack, Robert, and John Speweik  
1998 Repointing Mortar Joints in Historic Masonry Buildings. *Preservation Briefs, U.S. Department of the Interior* 1-16.
- Manganiello, Christopher  
2015 Lowell of the South. In *Southern Water, Southern Power: How the politics of cheap energy and water scarcity shaped a region*, edited by Christopher Manganiello, 21-44. University of North Carolina Press, Chapel Hill.
- Marx, Karl  
1859 *A Contribution to the Critique of Political Economy*. Progress Publishers, Moscow.  
1867 *Capital*. Progress Publishers, Moscow.
- Neale, Walter C.  
1998 Property: Law, cotton-pickin' hands, and implicit cultural imperialism. In *Property in Economic Context*, edited by R.C. Hunt and A. Gilman, 47-64. University Press American, Lanham, Maryland.
- North, Douglass  
1961 *The Economic Growth of the United States, 1790-1860*. Prentice Hall, Englewood Cliffs, California.
- Orange County Comptroller  
Property Deed Records, <http://www.occompt.com/>, accessed 2016.
- Orange County Property Appraiser

- GIS Data for property lines, <http://www.ocpaf1.org/>, accessed 2016.
- Pallett, Henry  
1866 *The Miller's, Millwright's, and Engineer's Guide*. Henry Clay Baird Industrial Publisher, Philadelphia.
- Phillips, John C.  
1998 Flood Thy Neighbor: Colonial and American Water-Powered Mills in West Florida. *Gulf South Historical Review* 14(1):143-157.
- Potter, Thomas  
1877 *Concrete: Its uses in building from foundations to finish*. E & F.N. Spon, London.
- Rennell, Rebecca  
2012 Landscape, Experience and GIS; Exploring the Potential for Methodological Dialogue. *Journal of Archaeological Method and Theory* 19(4):510-525.
- RICHES  
2010 Mosaic Interface, <https://richesmi.cah.ucf.edu/>, Accessed April 23, 2016.
- Robinson, Jim.  
2002 Howell Creek Homesteader Left a Giant Imprint on Area. *Orlando Sentinel* 19 May: Website Archives. Orlando.
- Ross, Charles P.  
2014 Water-Powered Mills. Florida Watermill Survey, Charles Ross, Maitland, Florida.
- Rucker, Brian  
1988 Arcadia and Bagdad: Industrial Parks of Antebellum Florida. *The Florida Historical Quarterly* 67(2):147-165.
- Schiffer, Michael Brian  
1992 *Technological Perspectives on Behavioral Change*. University of Arizona Press, Tucson.
- Sellett, Frederic  
1993 Chaîne Opératoire: The Concept and its Applications. *Lithic Technology* 18(1&2):106-112.
- Seminole County Property Appraiser  
GIS Data for property lines, <http://www.scpaf1.org/>, accessed 2016.
- Smith, Michael E.

- 1987 Household Possessions and Wealth in Agrarian States: Implications for Archaeology. *Journal of Anthropological Archaeology* 6(4):297-335.
- Sokoloff, Kenneth and Viken Tchakerian  
1997 Manufacturing Where Agriculture Predominates: Evidence from the South and Midwest in 1860. *Explorations in Economic History* 34(3):243-264.
- St. Johns River Water Management District.  
2007 Upper St. Johns River Basin Surface Water Improvement and Management Plan. Water Management, St. Johns River Water Management District.
- The Southern Historical Association  
1895 *Memoirs of Georgia*. The Southern Historical Association, Atlanta.
- United States Census  
1870 Census Records, [https://www.censusrecords.com/content/1870\\_Census](https://www.censusrecords.com/content/1870_Census), accessed March 3, 2016.
- USF Water Institute Seminole County  
2001 Seminole County Wateratlas, <http://www.seminole.wateratlas.usf.edu/>, accessed March 17, 2016.
- Vance, Rupert  
1968 *Human Geography of the South: A study in regional resources and human adequacy*. Russell & Russell, New York.
- Wehr, Paul  
2014 *Pine Castle: Stories of Orange County 1870-1890 as reported by William Wallace Harney*. Pine Castle Historical Society, Orlando.
- Winsburg, Morton  
2003 Climate Center FSU collection of weather data, <https://climatecenter.fsu.edu/products-services/data/precipitation/orlando>, accessed June 16, 2016.