

ART. XXI.—*The relative motion of the Earth and the Luminiferous ether*; by ALBERT A. MICHELSON, Master, U. S. Navy.

THE undulatory theory of light assumes the existence of a medium called the ether, whose vibrations produce the phenomena of heat and light, and which is supposed to fill all space. According to Fresnel, the ether, which is enclosed in optical media, partakes of the motion of these media, to an extent depending on their indices of refraction. For air, this motion would be but a small fraction of that of the air itself and will be neglected.

Assuming then that the ether is at rest, the earth moving through it, the time required for light to pass from one point to another on the earth's surface, would depend on the direction in which it travels.

Let V be the velocity of light.

v = the speed of the earth with respect to the ether.

D = the distance between the two points.

d = the distance through which the earth moves, while light travels from one point to the other.

d_1 = the distance earth moves, while light passes in the opposite direction.

Suppose the direction of the line joining the two points to coincide with the direction of earth's motion, and let T = time required for light to pass from the one point to the other, and T_1 = time required for it to pass in the opposite direction. Further, let T_0 = time required to perform the journey if the earth were at rest.

$$\text{Then } T = \frac{D+d}{V} = \frac{d}{v}; \text{ and } T_1 = \frac{D-d}{V} = \frac{d_1}{v}$$

From these relations we find $d = D \frac{v}{V-v}$ and $d_1 = D \frac{v}{V+v}$

whence $T = \frac{D}{V-v}$ and $T_1 = \frac{D}{V+v}$; $T - T_1 = 2T_0 \frac{v}{V}$ nearly, and
 $v = V \frac{T - T_1}{2T_0}$.

If now it were possible to measure $T - T_1$, since V and T_0 are known, we could find v the velocity of the earth's motion through the ether.

In a letter, published in "Nature" shortly after his death, Clerk Maxwell pointed out that $T - T_1$ could be calculated by measuring the velocity of light by means of the eclipses of Jupiter's satellites at periods when that planet lay in different directions from earth; but that for this purpose the observations of these eclipses must greatly exceed in accuracy those

which have thus far been obtained. In the same letter it was also stated that the reason why such measurements could not be made at the earth's surface was that we have thus far no method for measuring the velocity of light which does not involve the necessity of returning the light over its path, whereby it would lose nearly as much as was gained in going.

The difference depending on the square of the ratio of the two velocities, according to Maxwell, is far too small to measure.

The following is intended to show that, with a wave-length of yellow light as a standard, the quantity—if it exists—is easily measurable.

Using the same notation as before we have $T = \frac{D}{V-v}$ and $T_1 = \frac{D}{V+v}$. The whole time occupied therefore in going and

returning $T + T_1 = 2D \frac{V}{V^2 - v^2}$. If, however, the light had traveled in a direction at right angles to the earth's motion it would be entirely unaffected and the time of going and returning would be, therefore, $2 \frac{D}{V} = 2T_0$. The difference between the times $T + T_1$ and $2T_0$ is

$$2DV \left(\frac{1}{V^2 - v^2} - \frac{1}{V^2} \right) = \tau; \quad \tau = 2DV \frac{v^2}{V^2(V^2 - v^2)}$$

or nearly $2T_0 \frac{v^2}{V^2}$. In the time τ the light would travel a distance $V\tau = 2VT_0 \frac{v^2}{V^2} = 2D \frac{v^2}{V^2}$.

That is, the actual distance the light travels in the first case is greater than in the second, by the quantity $2D \frac{v^2}{V^2}$.

Considering only the velocity of the earth in its orbit, the ratio $\frac{v}{V} = \frac{1}{10\,000}$ approximately, and $\frac{v^2}{V^2} = \frac{1}{100\,000\,000}$. If $D = 1200$ millimeters, or in wave-lengths of yellow light, 2 000 000, then in terms of the same unit, $2D \frac{v^2}{V^2} = \frac{4}{100}$.

If, therefore, an apparatus is so constructed as to permit two pencils of light, which have traveled over paths at right angles to each other, to interfere, the pencil which has traveled in the direction of the earth's motion, will in reality travel $\frac{4}{100}$ of a wave-length farther than it would have done, were the earth at rest. The other pencil being at right angles to the motion would not be affected.

If, now, the apparatus be revolved through 90° so that the second pencil is brought into the direction of the earth's motion, its path will have lengthened $\frac{4}{100}$ wave-lengths. The total change in the position of the interference bands would be $\frac{8}{100}$ of the distance between the bands, a quantity easily measurable.

The conditions for producing interference of two pencils of light which had traversed paths at right angles to each other were realized in the following simple manner.

Light from a lamp *a*, fig. 1, passed through the plane parallel glass plate *b*, part going to the mirror *c*, and part being reflected to the mirror *d*. The mirrors *c* and *d* were of plane glass, and silvered on the front surface. From these the light was reflected to *b*, where the one was reflected and the other refracted, the two coinciding along *be*.

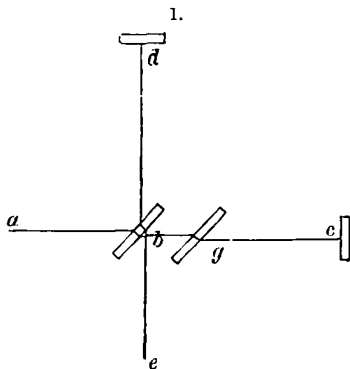

The distance *bc* being made equal to *bd*, and a plate of glass *g* being interposed in the path of the ray *bc*, to compensate for the thickness of the glass *b*, which is traversed by the ray *bd*, the two rays will have

traveled over equal paths and are in condition to interfere.

The instrument is represented in plan by fig. 2, and in perspective by fig. 3. The same letters refer to the same parts in the two figures.

The source of light, a small lantern provided with a lens, the flame being in the focus, is represented at *a*. *b* and *g* are the two plane glasses, both being cut from the same piece; *d* and *c* are the silvered glass mirrors; *m* is a micrometer screw which moves the plate *b* in the direction *bc*. The telescope *e*, for observing the interference bands, is provided with a micrometer eyepiece. *w* is a counterpoise.

In the experiments the arms, *bd*, *bc*, were covered by long paper boxes, not represented in the figures, to guard against changes in temperature. They were supported at the outer ends by the pins *k*, *l*, and at the other by the circular plate *o*. The adjustments were effected, as follows:

The mirrors *c* and *d* were moved up as close as possible to the plate *b*, and by means of the screw *m* the distances between a point on the surface of *b* and the two mirrors were made approximately equal by a pair of compasses. The lamp being

lit, a small hole made in a screen placed before it served as a point of light; and the plate *b*, which was adjustable in two planes, was moved about till the two images of the point of light, which were reflected by the mirrors, coincided. Then a sodium flame placed at *a* produced at once the interference bands. These could then be altered in width, position, or direction, by a slight movement of the plate *b*, and when they were of convenient width and of maximum sharpness, the

Fig. 2.

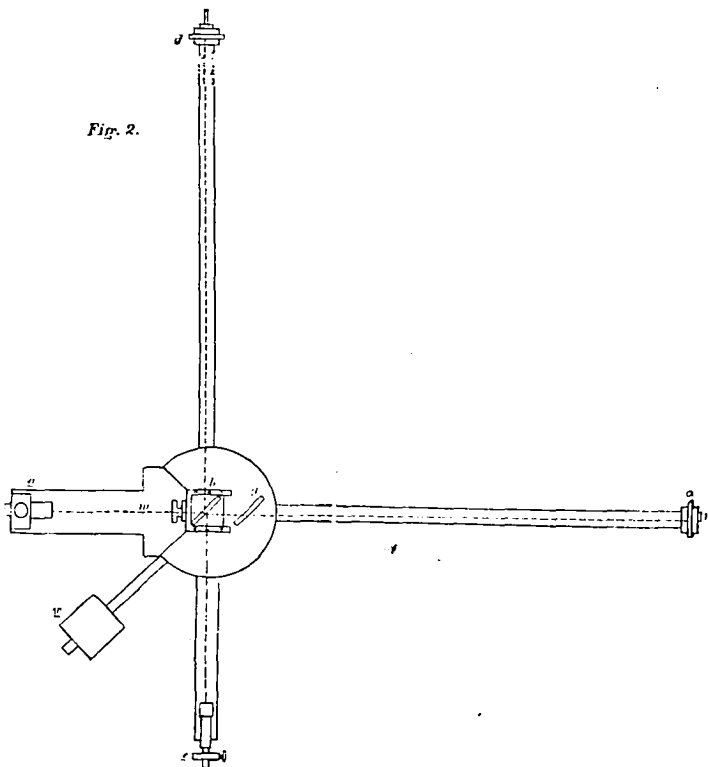

sodium flame was removed and the lamp again substituted. The screw *m* was then slowly turned till the bands reappeared. They were then of course colored, except the central band, which was nearly black. The observing telescope had to be focussed on the surface of the mirror *d*, where the fringes were most distinct. The whole apparatus, including the lamp and the telescope, was movable about a vertical axis.

It will be observed that this apparatus can very easily be

made to serve as an "interferential refractor," and has the two important advantages of small cost, and wide separation of the two pencils.

The apparatus as above described was constructed by Schmidt and Hænsch of Berlin. It was placed on a stone pier in the Physical Institute, Berlin. The first observation showed, however, that owing to the extreme sensitiveness of the instrument to vibrations, the work could not be carried on during the day. The experiment was next tried at night. When the mirrors were placed half-way on the arms the fringes were visible, but their position could not be measured till after twelve o'clock, and then only at intervals. When the mirrors were moved out to the ends of the arms, the fringes were only occasionally visible.

It thus appeared that the experiments could not be performed in Berlin, and the apparatus was accordingly removed

Fig. 3

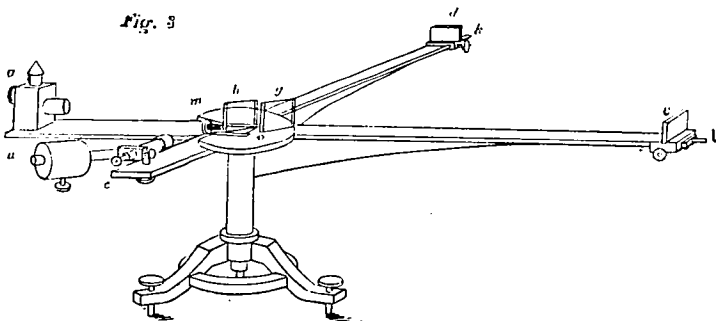

to the *Astrophysikalisches* Observatory in Potsdam. Even here the ordinary stone piers did not suffice, and the apparatus was again transferred, this time to a cellar whose circular walls formed the foundation for the pier of the equatorial.

Here, the fringes under ordinary circumstances were sufficiently quiet to measure, but so extraordinarily sensitive was the instrument that the stamping of the pavement, about 100 meters from the observatory, made the fringes disappear entirely!

If this was the case with the instrument constructed with a view to avoid sensitiveness, what may we not expect from one made as sensitive as possible!

At this time of the year, early in April, the earth's motion in its orbit coincides roughly in longitude with the estimated direction of the motion of the solar system—namely, toward the constellation Hercules. The direction of this motion is inclined at an angle of about $+26^{\circ}$ to the plane of the equator,

and at this time of the year the tangent of the earth's motion in its orbit makes an angle of $-23\frac{1}{2}^{\circ}$ with the plane of the equator; hence we may say the resultant would lie within 25° of the equator.

The nearer the two components are in magnitude to each other, the more nearly would their resultant coincide with the plane of the equator.

In this case, if the apparatus be so placed that the arms point north and east at noon, the arm pointing east would coincide with the resultant motion, and the other would be at right angles. Therefore, if at this time the apparatus be rotated 90° , the displacement of the fringes should be *twice* $\frac{8}{100}$ or 0.16 of the distance between the fringes.

If, on the other hand, the proper motion of the sun is small compared to the earth's motion, the displacement should be $\frac{1}{10}$ of .08 or 0.048. Taking the mean of these two numbers as the most probable, we may say that the displacement to be looked for is not far from one-tenth the distance between the fringes.

The principal difficulty which was to be feared in making these experiments, was that arising from changes of temperature of the two arms of the instrument. These being of brass whose coefficient of expansion is 0.000019 and having a length of about 1000 mm. or 1 700 000 wave-lengths, if one arm should have a temperature only one one-hundredth of a degree higher than the other, the fringes would thereby experience a displacement three times as great as that which would result from the rotation. On the other hand, since the changes of temperature are independent of the direction of the arms, if these changes were not too great their effect could be eliminated.

It was found, however, that the displacement on account of bending of the arms during rotation was so considerable that the instrument had to be returned to the maker, with instructions to make it revolve as easily as possible. It will be seen from the tables, that notwithstanding this precaution a large displacement was observed in one particular direction. That this was due entirely to the support was proved by turning the latter through 90° , when the direction in which the displacement appeared was also changed 90° .

On account of the sensitiveness of the instrument to vibration, the micrometer screw of the observing telescope could not be employed, and a scale ruled on glass was substituted. The distance between the fringes covered three scale divisions, and the position of the center of the dark fringe was estimated to fourths of a division, so that the separate estimates were correct to within $\frac{1}{12}$.

It frequently occurred that from some slight cause (among

others the springing of the tin lantern by heating) the fringes would suddenly change their position, in which case the series of observations was rejected and a new series begun.

In making the adjustment before the third series of observations, the direction in which the fringes moved, on moving the glass plate *b*, was reversed, so that the displacement in the third and fourth series are to be taken with the opposite sign.

At the end of each series the support was turned 90°, and the axis was carefully adjusted to the vertical by means of the foot-screws and a spirit level.

	N.	N.E.	E.	S.E.	S.	S.W.	W.	N.W.	Remarks.
1st revolution	0·0	0·0	0·0	-8·0	-1·0	-1·0	-2·0	-3·0	Series 1, footscrew marked B, toward East.
2d "	16·0	16·0	16·0	9·0	16·0	16·0	15·0	13·0	
3d "	17·0	17·0	17·0	10·0	17·0	16·0	16·0	17·0	
4th "	15·0	15·0	15·0	8·0	14·5	14·5	14·5	14·0	
5th "	13·5	13·5	13·5	5·0	12·0	13·0	13·0	13·0	
S.	61·5	61·5	61·5	x	58·5	58·5	56·5	54·0	
	58·5	W.	56·5		N.E.	61·5	S.E.	60·0	
	120·0		118·0			120·0		114·0	
	118·0					114·0			
Excess,	+2·0					+6·0			
1st revolution	10·0	11·0	12·0	13·0	13·0	0·0	14·0	15·0	Series 2, B toward South.
2d "	16·0	16·0	16·0	17·0	17·0	2·0	17·0	17·0	
3d "	17·5	17·5	17·5	17·5	17·5	4·0	18·0	17·5	
4th "	17·5	17·5	17·0	17·0	17·0	4·0	17·0	17·0	
5th "	17·0	17·0	17·0	17·0	16·0	3·0	16·0	16·0	
S.	78·0	79·0	79·5	81·5	80·5	x	82·0	82·5	
	80·5	W.	82·0		N.E.	79·0	S.E.	81·5	
	158·5		161·5			160·0		164·0	
	161·5					164·0			
Excess,	-3·0					-4·0			
1st revolution	3·0	3·0	3·0	3·0	2·5	2·5	2·5	10·0	Series 3, B toward West.
2d "	18·0	17·5	17·5	18·0	18·5	19·0	19·5	26·0	
3d "	11·0	11·0	13·0	12·0	13·0	13·5	13·5	21·0	
4th "	1·0	0·0	0·5	0·5	0·5	0·0	0·0	14·0	
5th "	4·0	4·0	5·0	5·0	5·0	5·5	5·5	16·0	
S.	37·0	35·5	39·0	38·5	39·5	40·5	71·0	x	
	39·5	W.	41·0		N.E.	35·5	S.E.	38·5	
	76·5		80·0			76·0		79·5	
			76·5					76·0	
Excess,			+3·5					+3·5	
1st revolution	14·0	21·0	15·5	17·0	14·0	14·5	14·5	16·0	Series 4, B toward North.
2d "	10·0	20·0	12·0	12·0	13·0	13·0	13·0	13·5	
3d "	14·0	25·0	15·0	16·0	16·0	16·0	16·0	17·0	
4th "	18·0	27·0	18·5	18·5	18·5	19·0	20·0	21·0	
5th "	15·0	24·0	15·0	15·0	15·0	16·0	16·0	16·5	
S.	71·0	x	76·0	78·5	76·5	78·5	79·5	84·0	
	76·5	W.	79·5		N.E.	73·5	S.E.	78·5	
	147·5		155·5			152·0		162·5	
			147·5					152·0	
Excess,			+8·0					+10·5	

The heading of the columns in the table gives the direction toward which the telescope pointed.

The footing of the erroneous column is marked x , and in the calculations the mean of the two adjacent footings is substituted.

The numbers in the columns are the positions of the center of the dark fringe in *twelfths* of the distance between the fringes.

In the first two series, when the footings of the columns N. and S. exceed those of columns E. and W., the excess is called positive. The excess of the footings of N.E., S.W., over those of N.W., S.E., are also called positive. In the third and fourth series this is reversed.

The numbers marked "excess" are the sums of ten observations. Dividing therefore by 10, to obtain the mean, and also by 12 (since the numbers are twelfths of the distance between the fringes), we find for

		N.S.	N.E., S.W.
Series 1	+ 0.017	+ 0.050
" 2	- 0.025	- 0.033
" 3	+ 0.030	+ 0.030
" 4	+ 0.067	+ 0.087
		4 <u>0.089</u>	<u>0.137</u>
Mean	=	+ 0.022	+ 0.034

The displacement is, therefore,

In favor of the columns	N.S.	+ 0.022
" " "	N.E., S.W.	+ 0.034

The former is too small to be considered as showing a displacement due to the simple change in direction, and the latter should have been zero.

The numbers are simply outstanding errors of experiment. It is, in fact, to be seen from the footings of the columns, that the numbers increase (or decrease) with more or less regularity from left to right.

This gradual change, which should not in the least affect the periodic variation for which we are searching, would of itself necessitate an outstanding error, simply because the sum of the two columns farther to the left must be less (or greater) than the sum of those farther to the right.

This view is amply confirmed by the fact that where the excess is positive for the column N.S., it is also positive for N.E., S.W., and where negative, negative. If, therefore, we can eliminate this gradual change, we may expect a much smaller error. This is most readily accomplished as follows:

Adding together all the footings of the four series, the third and fourth with negative sign, we obtain

N.	N.E.	E.	S.E.	S.	S.W.	W.	N.W.
31.5	31.5	26.0	24.5	23.0	20.8	18.0	11.0

or dividing by 20×12 to obtain the means in terms of the distance between the fringes,

N.	N.E.	E.	S.E.	S.	S.W.	W.	N.W.
0.131	0.131	0.108	0.102	0.096	0.086	0.075	0.046

If x is the number of the column counting from the right and y the corresponding footing, then the method of least squares gives as the equation of the straight line which passes nearest the points x, y —

$$y = 9.25x + 64.5$$

If, now, we construct a curve with ordinates equal to the difference of the values of y found from the equation, and the actual value of y , it will represent the displacements observed, freed from the error in question.

These ordinates are :

N.	N.E.	E.	S.E.	S.	S.W.	W.	N.W.
-0.002	-0.011	+0.003	-0.001	-0.004	-0.003	-0.001	+0.018
N.	-0.002	E.	+0.003	N.E.	-0.011	N.W.	+0.018
S.	-0.004	W.	-0.001	S.W.	-0.003	S.E.	-0.001
Mean =	-0.003		+0.001	Mean =	-0.007		+0.008
	+0.001				+0.008		
Excess =	-0.004			Excess =	-0.015		

The small displacements -0.004 and -0.015 are simply errors of experiment.

The results obtained are, however, more strikingly shown by constructing the actual curve together with the curve that should have been found if the theory had been correct. This is shown in fig. 4.

4.

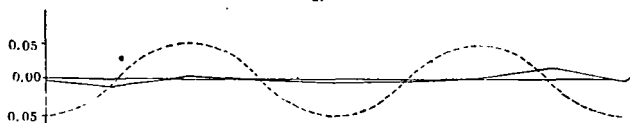

The dotted curve is drawn on the supposition that the displacement to be expected is one-tenth of the distance between the fringes, but if this displacement were only $\frac{1}{100}$, the broken line would still coincide more nearly with the straight line than with the curve.

The interpretation of these results is that there is no displacement of the interference bands. The result of the hypothesis of a stationary ether is thus shown to be incorrect, and the necessary conclusion follows that the hypothesis is erroneous.

This conclusion directly contradicts the explanation of the phenomenon of aberration which has been hitherto generally accepted, and which presupposes that the earth moves through the ether, the latter remaining at rest.

It may not be out of place to add an extract from an article published in the Philosophical Magazine by Stokes in 1846.

“All these results would follow immediately from the theory of aberration which I proposed in the July number of this magazine: nor have I been able to obtain any result admitting of being compared with experiment, which would be different according to which theory we adopted. This affords a curious instance of two totally different theories running parallel to each other in the explanation of phenomena. I do not suppose that many would be disposed to maintain Fresnel's theory, when it is shown that it may be dispensed with, inasmuch as we would not be disposed to believe, without good evidence, that the ether moved quite freely through the solid mass of the earth. Still it would have been satisfactory, if it had been possible to have put the two theories to the test of some decisive experiment.”

In conclusion, I take this opportunity to thank Mr. A. Graham Bell, who has provided the means for carrying out this work, and Professor Vogel, the Director of the *Astrophysisches Observatorium*, for his courtesy in placing the resources of his laboratory at my disposal.